



SHIELD™



M25U
USER MANUAL

Preface

Usage

The manual contains information on installing, using, operation and maintenance of the Modular UPS. Please carefully read this manual prior to installation.

Users

Technical Support Engineer
Maintenance Engineer

Note

Our company is providing a full range of technical support and services. Customer can contact our local office or customer service center for help. The manual will update irregularly, due to the product upgrading or other reasons.

Unless otherwise agreed, the manual is only used as guide for users and any statements or information contained in this manual make no warranty expressed or implied

Contents

Preface	II
Contents	II
1. Safety Precautions	IV
2. Overview	8
2.1. Product Description	8
2.2. System conceptual diagram	8
2.3. Power module conceptual diagram	8
2.4. Working Modes	9
2.4.1. Normal mode	9
2.4.2. Battery Mode	9
2.4.3. Bypass Mode	10
2.4.4. Maintenance Mode (Manual Bypass)	10
2.4.5. ECO Mode	11
2.4.6. Auto-restart Mode	12
2.4.7. Frequency Converter Mode	12
2.5. UPS Structure	12
2.5.1. UPS Configuration	12
2.5.2. UPS Structure	13
3. Installation	15
3.1. Location	15
3.1.1. Installation Environment	15
3.1.2. Site Selection	15
3.1.3. Weight and Dimensions	15
3.2. Unloading and Unpacking	17
3.2.1. Moving and Unpacking of the Cabinet	17
3.3. Positioning	18
3.4. Rack mounting	20
3.5. Switch between single input and double input of cabinet	23
3.6. Battery	24
3.7. Cable Entry	24
3.8. Power Cables	26
3.8.1. Specifications	26
3.8.2. Specifications for Power Cables Terminal	26
3.8.3. Circuit Breaker	27
3.8.4. Connecting Power Cables	27
3.9. Control and Communication Cables	28
3.9.1. Dry Contact Interface	34
3.9.2. Communication Interface	35
4. Operator Control and Display Panel	35
4.1. UPS operator panel	37
4.1.1. LED Indicator	37
4.1.2. Control operation key	38
4.1.3. LCD touch Screen	38

4.2	Main Menu.....	41
4.2.1	Cabinet	43
4.2.2	Power module.....	45
4.2.3	Setting	43
4.2.4	Log	45
4.2.5	Operate	54
4.2.6	Scope.....	53
5	Operations	54
5.1	UPS Start-up.....	54
5.1.1	Start in Normal Mode	54
5.1.2	Start from Battery	55
5.2	Procedure for Switching between Operation Modes	56
5.2.1	Switching the UPS into Battery Mode from Normal Mode	56
5.2.2	Switching the UPS from Normal Mode into Bypass Mode	56
5.2.3	Switching the UPS into Normal Mode from Bypass Mode	56
5.2.4	Switching the UPS from Normal Mode into Maintenance Bypass Mode.....	56
5.2.5	Switching the UPS into Normal Mode from Maintenance Bypass Mode	57
5.3	Battery Manual.....	57
5.4	EPO.....	58
5.5	Installation of Parallel Operation System	59
6	Maintenance.....	61
6.1	Contents of this chapter	61
6.2	System maintenance instruction	61
6.2.1	Matters needing attention	61
6.2.2	Instruction for Maintaining Power module	61
6.2.3	Maintaining monitor unit and bypass unit for 6-slot cabinet	61
6.2.4	Maintaining monitor unit and bypass unit for 8-slot cabinet	62
6.2.5	Battery maintenance	62
6	Product Specifications	64
7.1	Contents of this chapter	64
7.2	Applicable Standards.....	64
7.3	Environmental Characteristics	64
7.4	Mechanical Characteristic.....	65
7.5	Electrical Characteristics.....	65
7.5.1	Electrical Characteristics (Input Rectifier)	65
7.5.2	Electrical Characteristics (Intermediate DC Link)	65
7.5.3	Electrical Characteristics (Inverter Output)	66
7.5.4	Electrical Characteristics (Bypass Mains Input)	67
7.6	Efficiency	67
7.7	Display and Interface	68
	Appendix I.	68

1. Safety Precautions

This manual contains information concerning the installation and operation of the Modular UPS. Please carefully read this manual prior to installation.

The Modular UPS cannot be put into operation until it is commissioned by engineers approved by the manufacturer (or its agent). Not doing so could result in personnel safety risk, equipment malfunction and invalidation of warranty.

Safety Message Definition

Danger: Serious human injury or even death may be caused, if this requirement is ignored.



Warning: Human injury or equipment damage may be caused, if this requirement is ignored.

Attention: Equipment damage, loss of data or poor performance may be caused, if this requirement is ignored.





Commissioning Engineer: The engineer who installs or operates the equipment should be well trained in electricity and safety and familiar with the operation, debug, and maintenance of the equipment.

Warning Label



The warning label indicates the possibility of human injury or equipment damage, and advises the proper step to avoid the danger. In this manual, there are three types of warning labels as below.

Labels	Description
 Danger	Serious human injury or even death may be caused, if this requirement is ignored.
 Warning	Human injury or equipment damage may be caused, if this requirement is ignored.
 Attention	Equipment damage, loss of data or poor performance may be caused, if this requirement is ignored.

Safety Instruction

 Danger	<ul style="list-style-type: none"> ✧ Performed only by commissioning engineers. ✧ This UPS is designed for commercial and industrial applications only, and is not intended for any use in life-support devices or system.
 Warning	<ul style="list-style-type: none"> ✧ Read all the warning labels carefully before operation, and follow the instructions.
	<ul style="list-style-type: none"> ✧ When the system is running, do not touch the surface with this label, to avoid any hurt of scald.
	<ul style="list-style-type: none"> ✧ ESD sensitive components inside the UPS, anti-ESD measure should be taken before handling.

Move & Install

 Danger	<ul style="list-style-type: none"> ✧ Keep the equipment away from heat source or air outlets. ✧ In case of fire, use dry powder extinguisher only, any liquid extinguisher can result in electric shock.
 Warning	<ul style="list-style-type: none"> ✧ Do not start the system if any damage or abnormal parts founded. ✧ Contacting the UPS with wet material or hands may be subject to electric shock.
 Attention	<ul style="list-style-type: none"> ✧ Use proper facilities to handle and install the UPS. Shielding shoes, protective clothes and other protective facilities are necessary to avoid injury. ✧ During positioning, keep the UPS way from shock or vibration. ✧ Install the UPS in proper environment, more detail in section 3.3.

Debug & Operate

 Danger	<ul style="list-style-type: none"> ✧ Make sure the grounding cable is well connected before connecting the power cables, the grounding cable and neutral cable must be in accordance with the local and national codes practice. ✧ Before moving or re-connecting the cables, make sure to cut off all the input power sources, and wait for at least 10 minutes for internal discharge. Use a multi-meter to measure the voltage on terminals and ensure the voltage is lower than 36V before operation. ✧ Risk of Voltage Back feed. Before working on the circuits, isolate the Uninterruptible Power Supply (UPS), and then check for Hazardous Voltage between all terminals including the protective earth.
---------------------------------------------------------------------------------------------------	-----------------------------------------------------------------------------------------------------------------------------------------------------------------------------------------------------------------------------------------------------------------------------------------------------------------------------------------------------------------------------------------------------------------------------------------------------------------------------------------------------------------------------------------------------------------------------------------------------------------------------------------------------------------------------------------------------------------------------------------------------------

 Attention	<ul style="list-style-type: none"> ◇ The earth leakage current of load will be carried by RCCB or RCD. ◇ Initial check and inspection should be performed after long time storing of UPS.
-------------------------------------------------------------------------------------------------------	-------------------------------------------------------------------------------------------------------------------------------------------------------------------------------------------------------------------

Maintenance & Replacement

 Danger	<ul style="list-style-type: none"> ◇ All the equipment maintenance and servicing procedures involving internal access need special tools and should be carried out only by trained personnel. The components that can only be accessed by opening the protective cover with tools cannot be maintained by user. ◇ This UPS full complies with "IEC62040-1-1-General and safety requirements for use in operator access area UPS". Dangerous voltages are present within the battery box. However, the risk of contact with these high voltages is minimized for non-service personnel. Since the component with dangerous voltage can only be touched by opening the protective cover with a tool, the possibility of touching high voltage component is minimized. No risk exists to any personnel when operating the equipment in the normal manner, following the recommended operating procedures in this manual. ◇ Risk of Fire. TO REDUCE THE RISK OF RIFE, REPLACE FUSES WITH THE SAME TYPE AND RATINGS. DISCONNECT OUTPUT AND ALL INPUT SOURCES OF POWER FROM THIS EQUIPMENT BEFORE SERVICING.
----------------------------------------------------------------------------------------------------	------------------------------------------------------------------------------------------------------------------------------------------------------------------------------------------------------------------------------------------------------------------------------------------------------------------------------------------------------------------------------------------------------------------------------------------------------------------------------------------------------------------------------------------------------------------------------------------------------------------------------------------------------------------------------------------------------------------------------------------------------------------------------------------------------------------------------------------------------------------------------------------------------------------------------------------------------------------------------------------------------------------------------------------------------------------------------------------------------------------------------------------------

Battery Safety

 Danger	<ul style="list-style-type: none"> ◇ All the battery maintenance and servicing procedures involving internal access need special tools or keys and should be carried out only by trained personnel. ◇ WHEN CONNECTED TOGETHER, THE BATTERY TERMINAL VOLTAGE WILL EXCEED 400Vdc AND IS POTENTIALLY LEATHAL. ◇ Battery manufacturers supply details of the necessary precautions to be observed when working on, or in the vicinity of, a large bank of battery cells. These precautions should be followed implicitly at all times. Particular attention should be paid to the recommendations concerning local environmental conditions and the provision of protective clothing, first aid and fire-Figure ting facilities. ◇ Ambient temperature is a major factor in determining the battery capacity and life. The nominal operating temperature of battery is 20°C. Operating above this temperature will reduce the battery life. Periodically change the battery according to the battery user manuals to ensure the back-up time of UPS.
------------------------------------------------------------------------------------------------------	--------------------------------------------------------------------------------------------------------------------------------------------------------------------------------------------------------------------------------------------------------------------------------------------------------------------------------------------------------------------------------------------------------------------------------------------------------------------------------------------------------------------------------------------------------------------------------------------------------------------------------------------------------------------------------------------------------------------------------------------------------------------------------------------------------------------------------------------------------------------------------------------------------------------------------------------------------------------------------------------------------------------------------------------------------------------------------------------

	<ul style="list-style-type: none"> ✧ Replace the batteries only with the same type and the same number, or it may cause explosion or poor performance. ✧ When connecting the battery, follow the precautions for high-voltage operation before accepting and using the battery, check the appearance the battery. If the package is damaged, or the battery terminal is dirty, corroded or rusted or the shell is broken, deformed or has leakage, replace it with new product. Otherwise, battery capacity reduction, electric leakage or fire may be caused. <ul style="list-style-type: none"> ● Before operating the battery, remove the finger ring, watch, necklace, bracelet and any other metal jewelry ● Wear rubber gloves. ● Eye protection should be worn to prevent injury from accidental electrical arcs. ● Only use tools (e.g. wrench) with insulated handles. ● The batteries are very heavy. Please handle and lift the battery with proper method to prevent any human injury or damage to the battery terminal. ● Do not decompose, modify or damage the battery. Otherwise, battery short circuit, leakage or even human injury may be caused. ● The battery contains sulfuric acid. In normal operation, all the sulfuric acid is attached to the separation board and plate in the battery. However, when the battery case is broken, the acid will leak from the battery. Therefore, be sure to wear a pair of protective glasses, rubber gloves and skirt when operating the battery. Otherwise, you may become blind if acid enters your eyes and your skin may be damaged by the acid. ● At the end of battery life, the battery may have internal short circuit, drain of electrolytic and erosion of positive/negative plates. If this condition continues, the battery may have temperature out of control, swell or leak. Be sure to replace the battery before these phenomena happen. ● If a battery leaks electrolyte, or is otherwise physically damaged, it must be replaced, stored in a container resistant to sulfuric acid and disposed of in accordance with local regulations. ● If electrolyte comes into contact with the skin, the affected area should be washed immediately with water.
--	------------------------------------------------------------------------------------------------------------------------------------------------------------------------------------------------------------------------------------------------------------------------------------------------------------------------------------------------------------------------------------------------------------------------------------------------------------------------------------------------------------------------------------------------------------------------------------------------------------------------------------------------------------------------------------------------------------------------------------------------------------------------------------------------------------------------------------------------------------------------------------------------------------------------------------------------------------------------------------------------------------------------------------------------------------------------------------------------------------------------------------------------------------------------------------------------------------------------------------------------------------------------------------------------------------------------------------------------------------------------------------------------------------------------------------------------------------------------------------------------------------------------------------------------------------------------------------------------------------------------------------------------------------------------------------------------------------------------------------------------------------------------------------------------------------------------------------------------------------------------------------------------------------------------------------------------------------------------------------------------------------------------------------------------------------------------------------------------------------------------------------------------------------------------------------------------------------------------------------------------------------------------------------------------------------------------------------------------------------------------------

Disposal

	<p>Warning</p>	<ul style="list-style-type: none"> ✧ Dispose of used battery according to the local instructions
-------------------------------------------------------------------------------------	-----------------------	-----------------------------------------------------------------------------------------------------------------

2. Overview

2.1. Product Description

The RM series Modular UPS is an online double-conversion UPS that uses digital signal processing (DSP) technology. Provide a stable and uninterrupted power supply for the important load.

2.2. System conceptual diagram

The Modular UPS is configured by the following part: Power modules, Bypass & Monitoring unit, and cabinet with manual Bypass switch. One or several battery strings should be installed to provide backup energy once the utility fails. The UPS structure is shown in Figure 2-1:

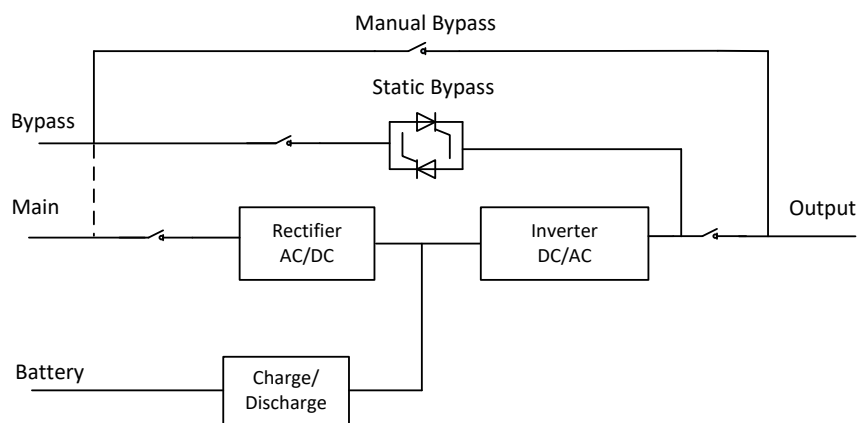

Figure 2-1 UPS Conceptual Diagram

2.3. Power module conceptual diagram

The power module conceptual diagram is shown as Figure 2-2. The Power module contains a rectifier, an inverter, and a DC/DC converter for charge and discharge of the external batteries.

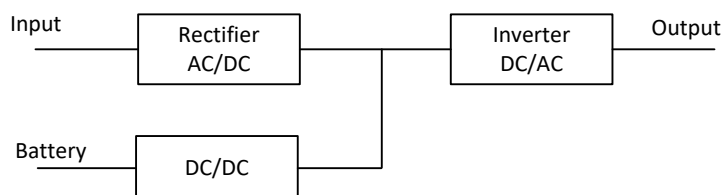

Figure 2-2 Power module conceptual diagram

2.4. Working Modes

The Modular UPS is an on-line, double-conversion UPS that permits operation in the following modes:

- Normal mode
- Battery mode
- Bypass mode
- Maintenance mode (manual bypass)
- ECO mode
- Auto-restart mode
- Frequency Converter mode

2.4.1. Normal mode

The inverter of power modules continuously supply the critical AC load. The rectifier/charger derives power from the AC mains input source and supplies DC power to the inverter while simultaneously FLOAT or BOOST charging its associated backup battery. As Figure 2-3 shows

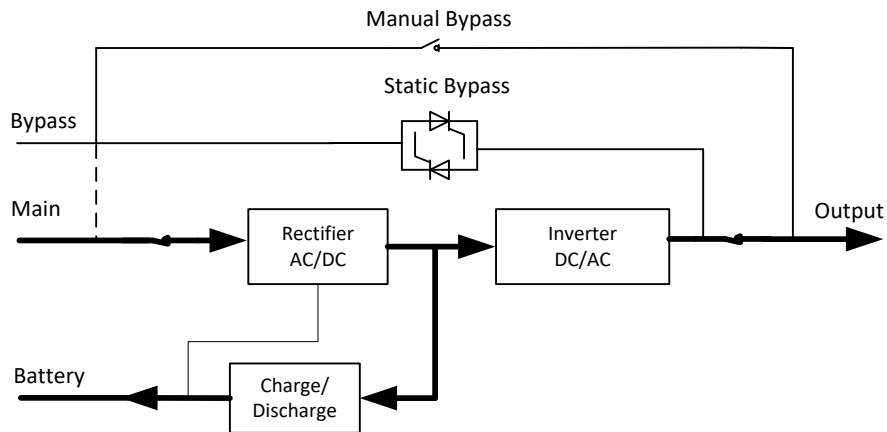

Figure 2-3 UPS conceptual diagram in normal mode

○ **Note**

➔ Indicates the energy flow direction.

2.4.2. Battery Mode

Upon failure of the AC mains input power, the inverter of power module, which obtains power from the battery, supply the critical AC load. There is no interruption in power to the critical load upon failure. After restoration of the AC mains input power, the “Normal mode” operation will continue automatically without the necessity of user intervention. As Figure 2-4 shows.

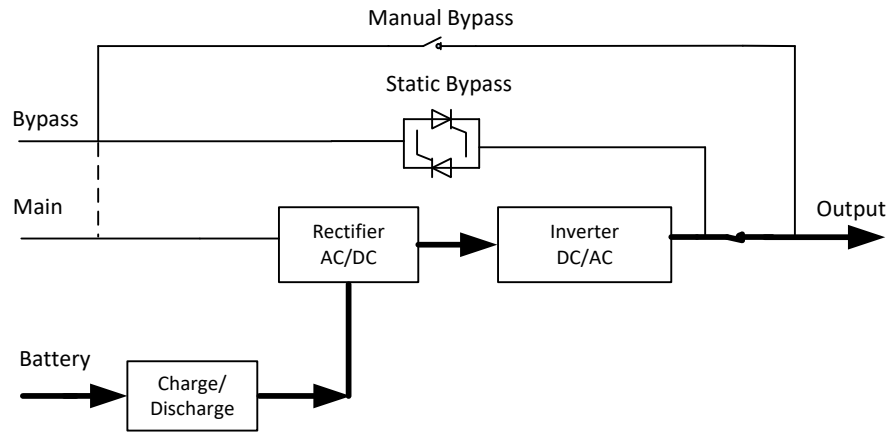

Figure 2-5 UPS conceptual diagram in Battery mode

○ **Note**

With the function of Battery cold start, the UPS may start without utility.

2.4.3. Bypass Mode

If the inverter overload capacity is exceeded under Normal mode, or if the inverter becomes unavailable for any reason, the static transfer switch will perform a transfer of the load from the inverter to the bypass source, with no interruption in power to the critical AC load. Should the inverter be asynchronous with the bypass, the static switch will perform a transfer of the load from the inverter to the bypass with power interruption to the load. This is to avoid large cross currents due to the paralleling of unsynchronized AC sources. This interruption is programmable but typically set to be less than 3/4 of an electrical cycle, e.g., less than 15ms (50Hz) or less than 12.5ms (60Hz). The action of transfer/re-transfer can also be done by the command through monitor. As Figure 2-6 shows.

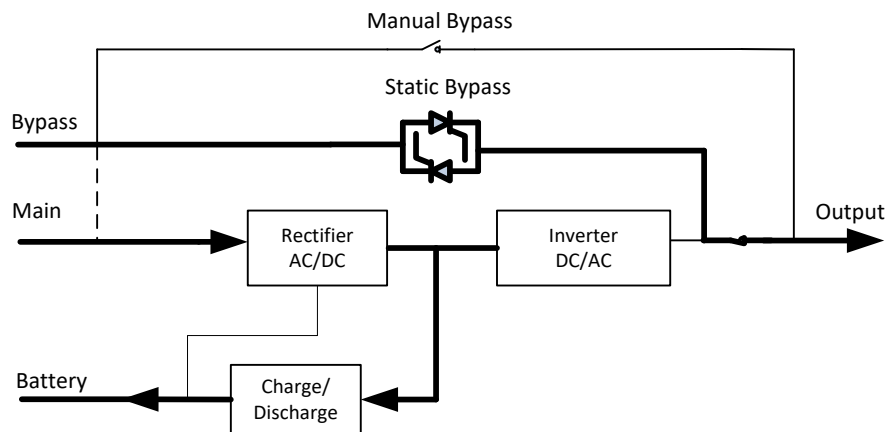

Figure 2-6 UPS conceptual diagram in Bypass Mode

2.4.4. Maintenance Mode (Manual Bypass)

A manual bypass switch is available to ensure continuity of supply to the critical load when the UPS becomes unavailable e.g. during a maintenance procedure. As Figure 2-7 shows.

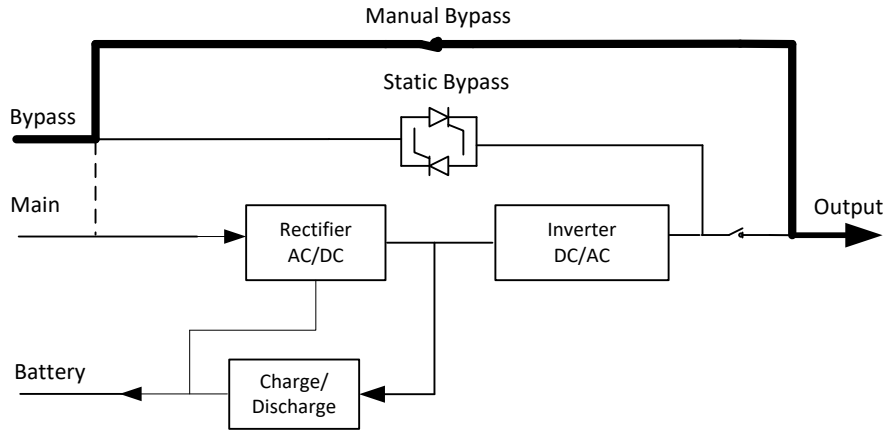

Figure 2-7 UPS conceptual diagram in Maintenance Mode



Danger

- During Maintenance mode, dangerous voltages are present on the terminal of input, output and neutral, even with all the modules and the LCD turned off.
- The UPS which without External maintenance switch in Maintenance Mode, dangerous voltages are present on terminal and internal Copper bar.

2.4.5. ECO Mode

The economy control operation (ECO) mode is an energy-saving mode, In ECO mode, when the bypass input voltage is within the ECO voltage range, the static bypass turns on, and the bypass supplies power, and inverter is standby. When the bypass input voltage is beyond the ECO voltage range, the UPS transfers from bypass mode to normal mode. As Figure 2-8 shows.

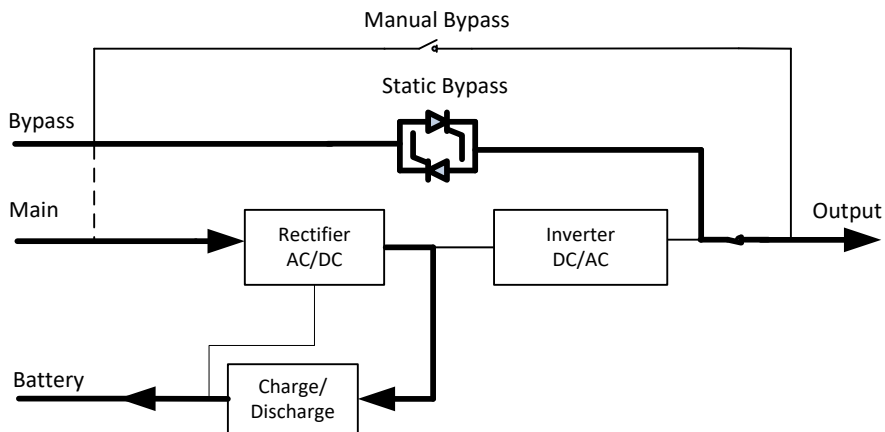

Figure 2-8 UPS conceptual diagram in ECO Mode

2.4.6. Auto-restart Mode

The battery may become exhausted following an extended AC mains failure. The inverter shuts down when the battery reaches the End of Discharge Voltage (EOD). The UPS may be programmed to “System Auto-Start Mode after EOD”. The system starts after a delay time when the AC main recovers. The mode and the delay time are programmed by the commissioning engineer.

2.4.7. Frequency Converter Mode

By setting the UPS to Frequency Converter mode, the UPS could present a stable output of fixed frequency (50 or 60Hz), and the bypass static switch is not available.

2.5. UPS Structure

2.5.1. UPS Configuration

The UPS configuration is provided in Table 2-1.

Table 2-1 UPS Configuration

Item	Components	Quantity/ pcs	Remark
6-slot Cabinet	Bypass & Monitoring unit	1	factory installed
8-slot Cabinet	Manual Bypass Breaker	1	factory installed
	Bypass & Monitoring unit	1	factory installed
25kVA Power module	Bypass unit	1~8	/

2.5.2. UPS Structure

The UPS structure is shown in Figure 2-9.

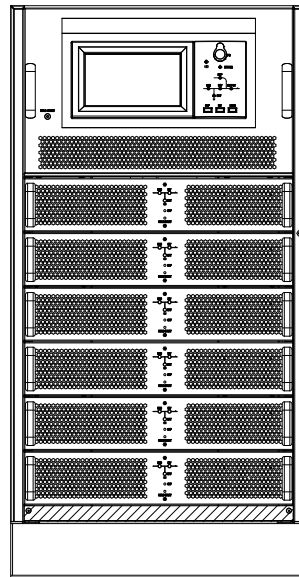

(a) 6-slot UPS Cabinet structure

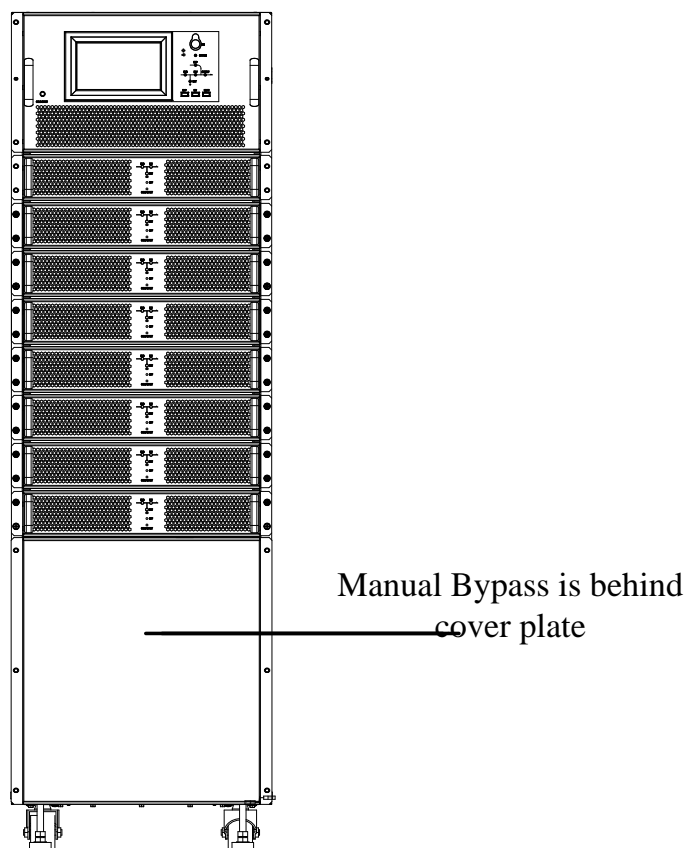

(b) 8-slot UPS Cabinet structure

Figure 2-9 UPS Cabinet structure (front view)

Back view as Figure 2-10 shows.

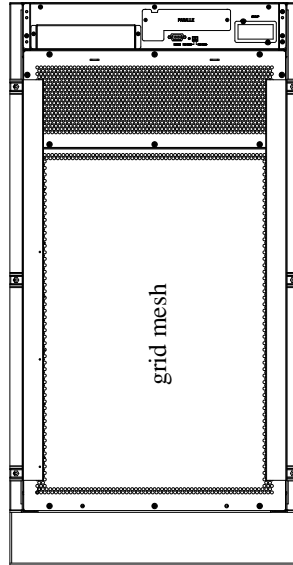

(a) 6 slot UPS Cabinet structure (back view)

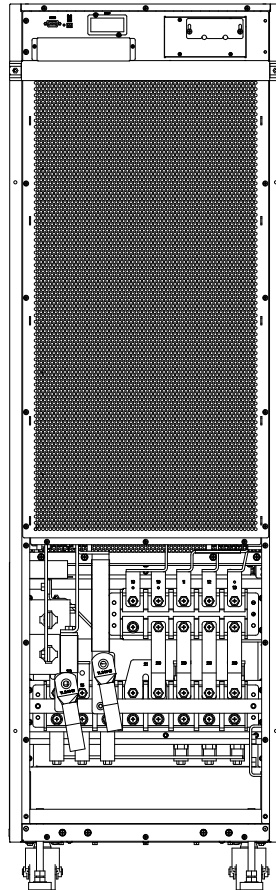

(b) 8 slot UPS Cabinet structure (back view)

Figure 2-10 UPS Cabinet structure (back view)

3. Installation

3.1. Location

As each site has its requirements, the installation instructions in this section are to act as a guide for the general procedures and practices that should be observed by the installing engineer

3.1.1. Installation Environment

- The UPS is intended for indoor installation and uses forced convection cooling by internal fans. Please make sure there is enough space for the UPS ventilation and cooling.
- Keep the UPS far away from water, heat and inflammable and explosive, corrosive material. Avoid installing the UPS in the environment with direct sunlight, dust, volatile gases, corrosive material and high salinity.
- Avoid installing the UPS in the environment with conductive dirt.
- The operating environment temperature for battery is 20°C-25°C. Operating above 25°C will reduce the battery life, and operation below 20°C will reduce the battery capacity.
- The battery will generate a little amount of hydrogen and oxygen at the end of charging; ensure the fresh air volume of the battery installation environment must meet EN50272-2001 requirements.
- If external batteries are to be used, the battery circuit breakers (or fuses) must be mounted as close as possible to the batteries, and the connecting cables should be as short as possible.

3.1.2. Site Selection

Ensure the ground or installation platform can bear the weight of the UPS cabinet, batteries and battery rack.



Attention

The UPS cabinet, battery can battery racks are suitable for mounting on concrete or other non-combustible surface on

No vibration and less than 5 degree inclination horizontally.

The equipment should be stored in a room so as to protect it against excessive humidity and heat sources.

The battery needs to be stored in dry and cool place with good ventilation. The most suitable storage temperature is 20 °C to 25°C.

3.1.3. Weight and Dimensions



Attention

Ensure there is at least 0.8m before the front of the cabinet so as to easily maintain the power module

with the front door fully open and at least 0.5m behind for ventilation and cooling.

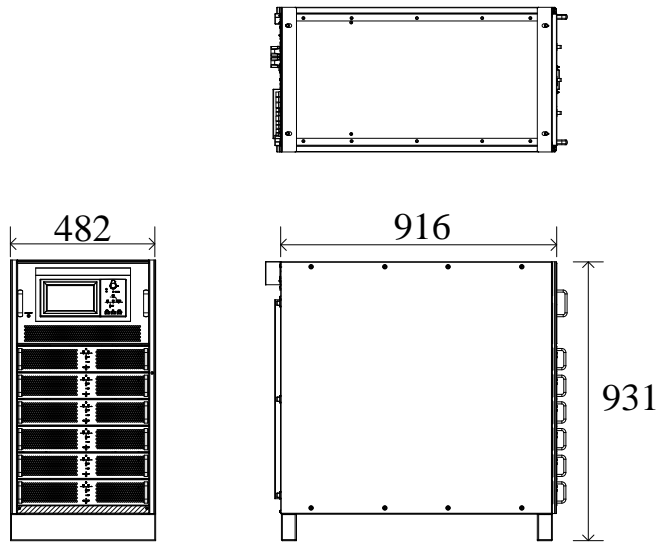

(a) Dimensions of 6-slot Cabinet (unit: mm)

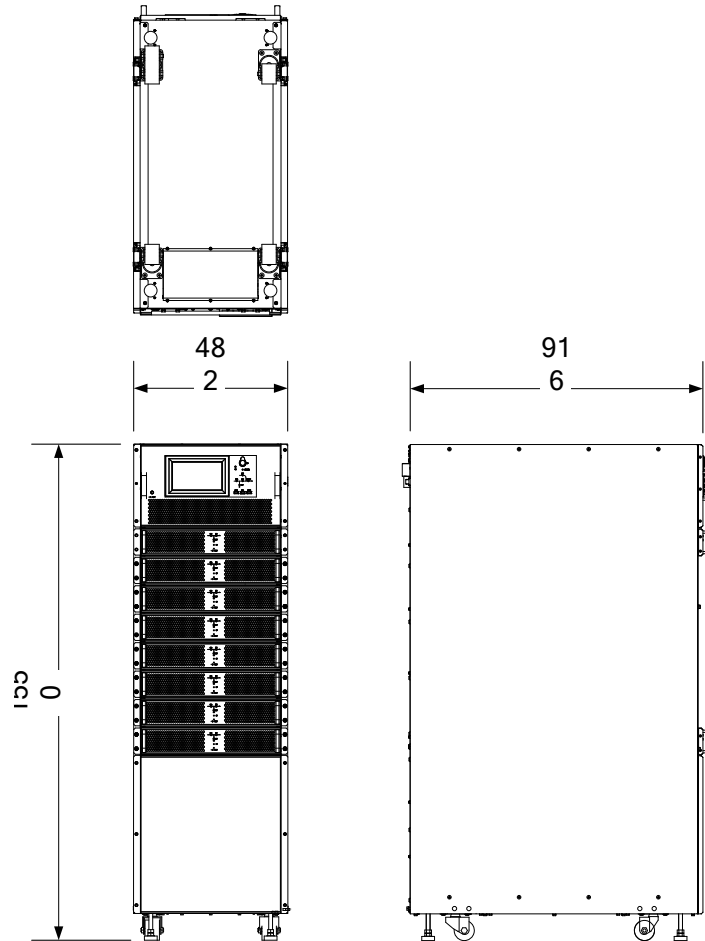

(b) Dimensions of 8-slot Cabinet (unit: mm)

Figure 3-1 Dimensions of Cabinet (unit: mm)

Ensure that the floor or installation support can bear the weight of the UPS, batteries,

and battery racks. The weight of batteries and battery racks depends on the site requirements. The weight for the UPS cabinet is shown in Table 3-1.

Table 3-1 Weight for the UPS

Capacity	Weight
PM25C	18Kg
6-slot Cabinet	116Kg
8-slot Cabinet	200Kg

3.2. Unloading and Unpacking

3.2.1. Moving and Unpacking of the Cabinet

The steps to move and unpack the cabinet are as follows :

- 1) Check if any damages to the packing. (If any, contact to the carrier)
- 2) Transport the equipment to the designated site by forklift, as shown in Figure 3-2 :

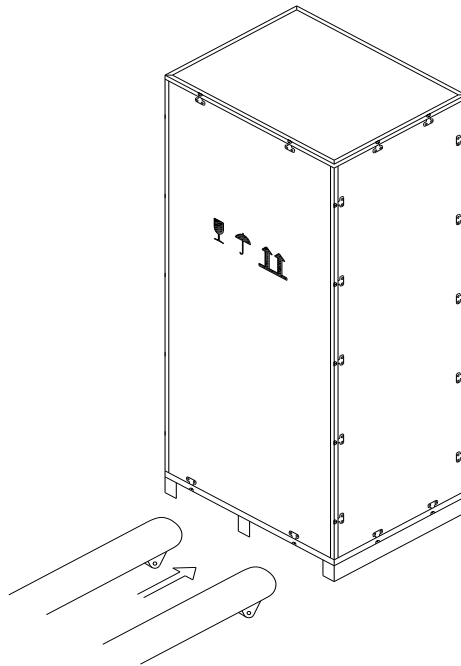

Figure 3-2 Transport to the designated site

- 3) Open the top plate of the steel-edged wooden case with slotted awl and pier, followed by sideboards (see Figure 3-3 ;

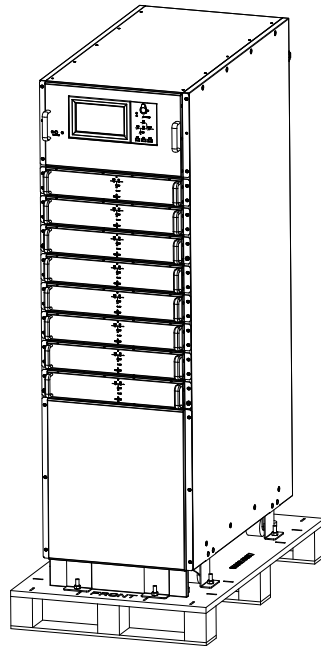

Figure 3-3 Remove the protective foam

- 4) Remove the protective foam around the cabinet.
- 5) Check the UPS.
Visually examine if there are any damages to UPS during transportation. If any, contact to the carrier. ;

Check the UPS with the list of the goods. If any items are not included in the list, contact to our company or the local office

- 6) Dismantle the bolt that connects the cabinet and wooden pallet after disassembly.
- 7) Move the cabinet to the installation position.



Attention

Be careful while removing to avoid scratching the equipment.



Attention

The waste materials of unpacking should be disposed to meet the demand for environmental protection.

3.3. Positioning

The 8-slot cabinet has two way of supporting itself: One is to support itself temporarily by the four wheels at the bottom, making it convenient to adjust the position of the cabinet; the other is by anchor bolts to support the cabinet permanently after adjusting the position of the cabinet. The 6-slot cabinet has stationary barrier, it does not have wheels. The supporting structure is shown in Figure 3-4.

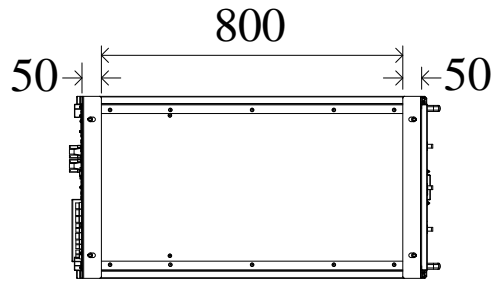

(a) Supporting structure of 6-slot Cabinet (Bottom view, unit: mm)

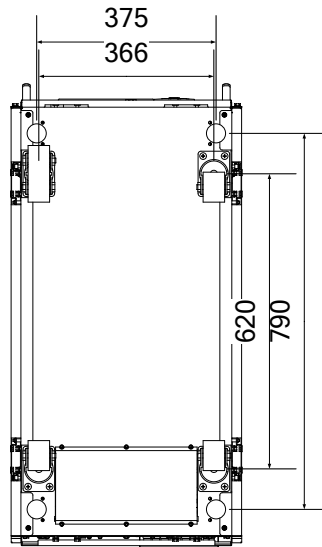

(b) Supporting structure of 8-slot Cabinet (Bottom view, unit: mm)

Figure 3-4 Supporting structure (Bottom view)

When installing the 6-slot UPS, use the fork lift truck to transport the cabinet directly to the installation position.

The steps to position the 8-slot cabinet are as follows :

- 1) Ensure the supporting structure is in good condition and the mounting floor is smooth and strong.
- 2) Retract the anchor bolts by turning them counter clock wise using wrench. The cabinet is then supported by the four wheels.
- 3) Adjust the cabinet to the right position by the supporting wheels.
- 4) Put down the anchor bolts by turning them clock wise using wrench, the cabinet is then supported by the four anchor bolts.
- 5) Ensure the four anchor bolts are in the same height and the cabinet is fixed and immovable.
- 6) Positioning done.



Attention

- Auxiliary equipment is needed when the mounting floor is not solid enough to support the cabinet, which helps distribute the weight over a larger area. For instance, cover the floor with iron plate or increase the supporting area of the anchor bolts.
- Reserve at least 0.8 meters in front of the cabinet to replace the power module and bypass module. The cabinet should be reserved for at least 0.5 meters space in back for air flow and heat

dissipation, As Figure 3-5 shows.

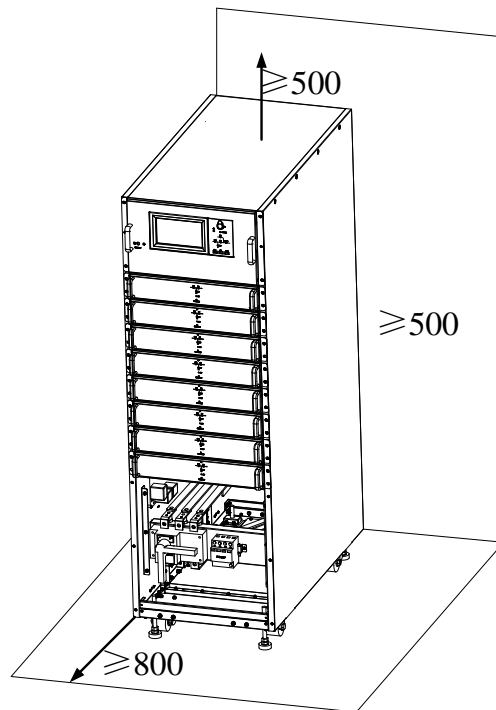

Figure 3-5 Cabinet space reservation schematic (unit: mm)

3.4. Rack mounting

The UPS system supports rack mounting to meet the application requirements of the micro modular machine room.

The specific procedures for installing the UPS rack are as follows :

1. Remove cabinet trim strip, as Figure 3-6 shows ;

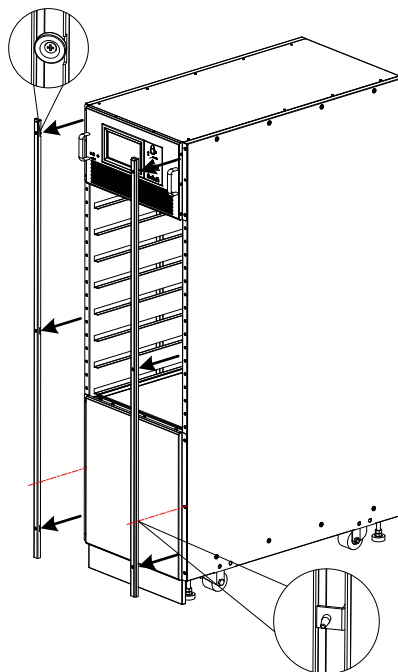

Figure 3-6 Remove cabinet trim strip

2. Remove the side door of the cabinet, as Figure 3-7 shows ;

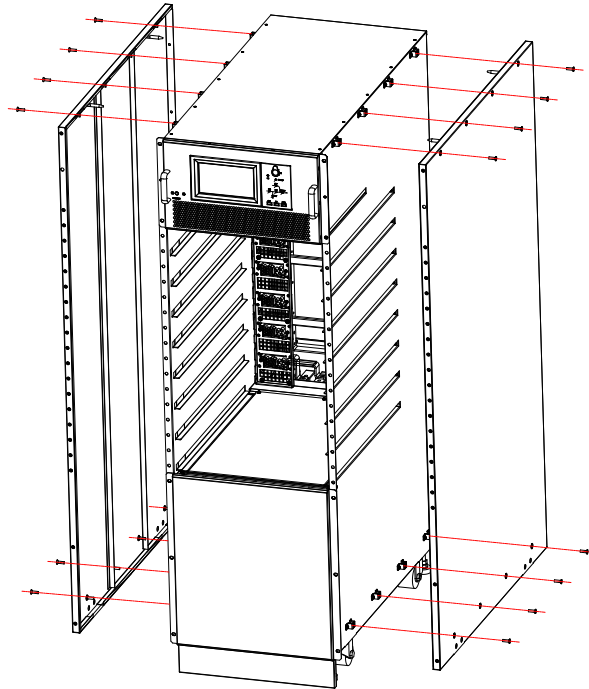

Figure 3-7 Remove the side door of the cabinet

3. Remove bracket for cabinet side door, as Figure 3-8 shows ;

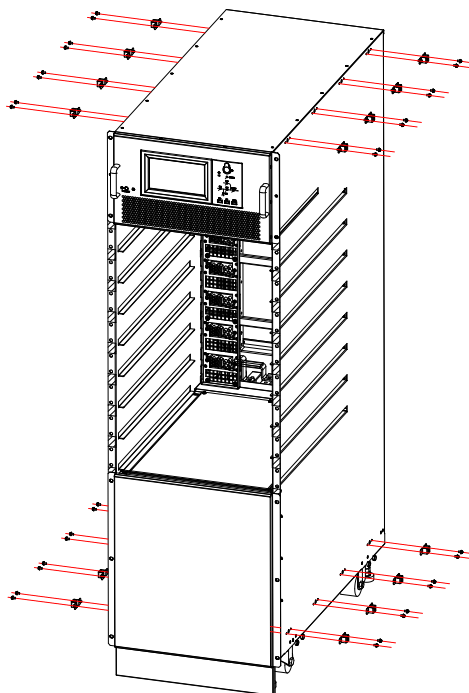

Figure 3-8 Remove bracket for cabinet side door

4. Install rack tray on the server cabinet, as Figure 3-9 shows ;

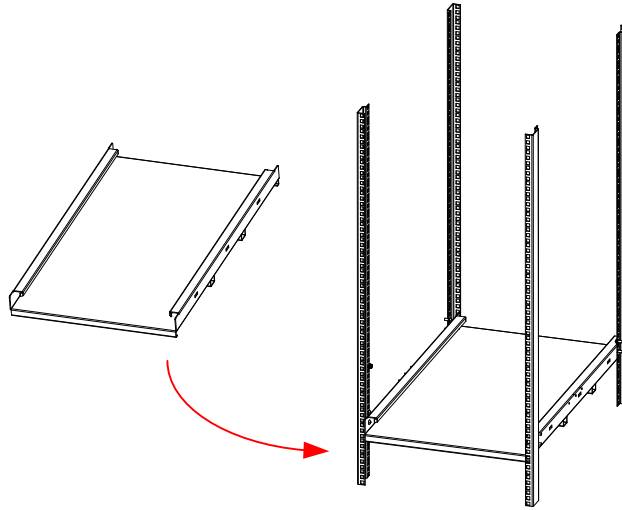

Figure 3-9 Install rack tray

5. Load the UPS into the server cabinet, place on rack tray, and lock the bypass module and the manual bypass switch panel screws(6-slot cabinet needs to remove stationary barrier first), as Figure 3-10 shows ;

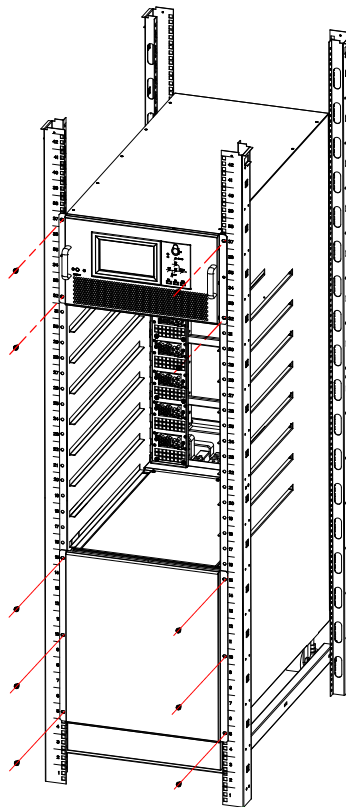

Figure 3-10 Load the UPS into the server cabinet

6. Insert module to cabinet, and lock the module panel screws, as Figure 3-11 shows ;

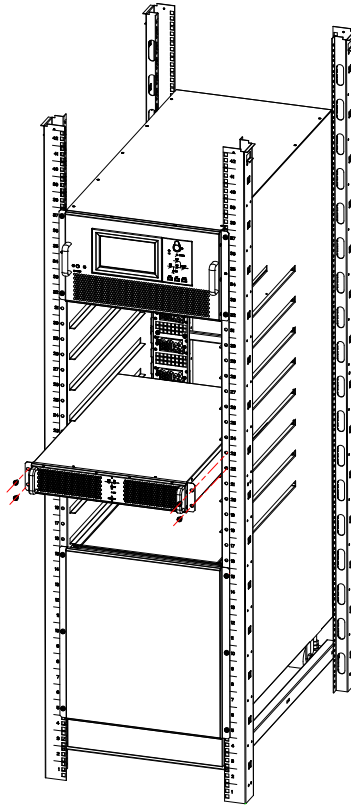

Figure 3-11 Insert module to cabinet

7. Complete installation.

3.5. Switch between single input and double input of cabinet

When the UPS cabinet leaves the factory, it defaults to a single input configuration.

The 6-slot cabinet needs to be matched with PDU to have dual input function and can only be configured by the manufacturer.

8 Change single input to dual input , just need to remove the main input and the bypass input short connecting copper bar. As Figure 3-12 shows.

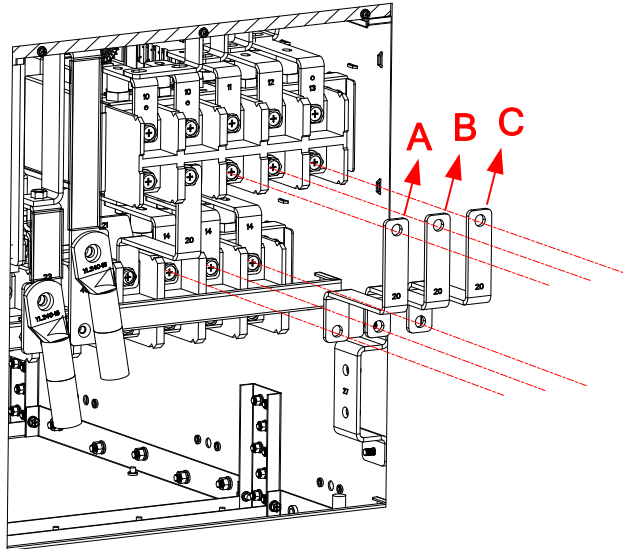

Figure 3-12 Remove the main input and the bypass input short connecting copper bar

3.6. Battery

Three terminals (positive, neutral, negative) are drawn from the battery unit and connected to UPS system. The neutral line is drawn from the middle of the batteries in series. See Figure 3-13

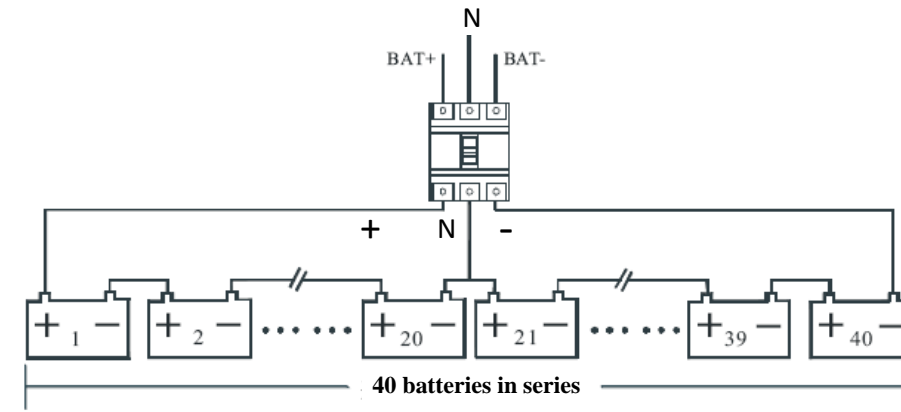

Figure 3-13 Battery string wiring diagram



Danger

The battery terminal voltage is of more than 200Vdc, please follow the safety instructions to avoid electric shock hazard.

Ensure the positive, negative, neutral electrode is correctly connected from the battery unit terminals to the breaker and from the breaker to the UPS system.

3.7. Cable Entry

Cables can enter the 6-slot cabinet from the top; can enter the 6-slot cabinet from the bottom. The

cable entry is shown in Figure 3-14.

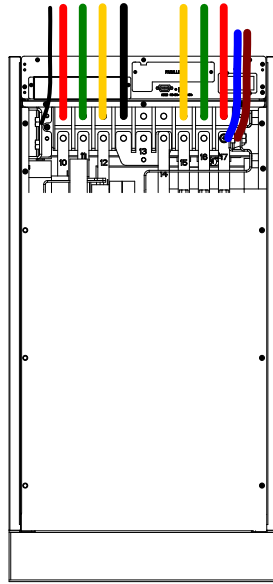

(a) cable Entry of 6-slot Cabinet

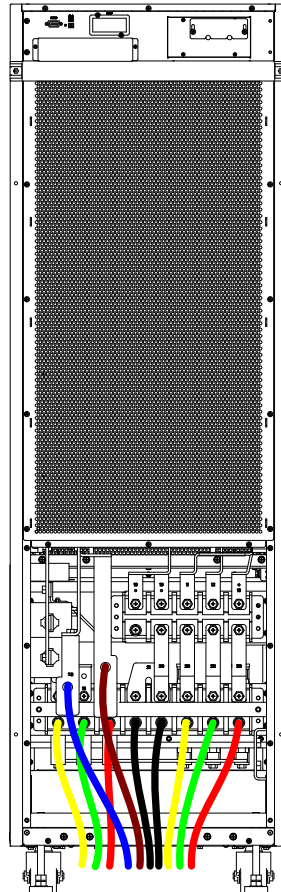

(b) cable Entry of 8-slot Cabinet

Figure 3-14 Cable Entry

3.8. Power Cables

3.8.1. Specifications

The selection of power cable in UPS system should meet the requirements of Table 3B in IEC60950-1, and select suitable cable in combination with practical engineering applications, UPS working current shows in Table 3-2.

Table 3-2 UPS working current

Contents		6-solt cabinet	8-solt cabinet
Main Input	Main Input Current(A)	293	391
Main Input	Main output Current(A)	227	303
Bypass Input	Bypass Input Current(A)	227	303
Battery input	Battery Input Current(A)	340	453

○ **Note**

The recommended cable section for power cables are only for situations described below :

- Ambient temperature : 30°C.
- AC loss less than 3%, DC loss less than 1%, The length of the AC power cables are no longer than 50 m and the length of the DC power cables are no longer than 30 m.
- Currents listed in the table are based on the 380V system (Line-to-line voltage).
- The size of neutral lines should be 1.5~1.7 times the value listed above when the predominant load is non-linear.

3.8.2. Specifications for Power Cables Terminal

Specifications for power cables connector are listed as Table 3-3.

Table 3-3 Requirements for power module terminal

Cabinet	Port	Connection	Type	Bolt	Torque Moment
6-slot	Mains input	Cables crimped terminal OT	150-10	M10	15Nm
	Bypass Input	Cables crimped terminal OT	150-10	M10	15Nm
	Battery Input	Cables crimped terminal OT	150-10	M10	15Nm
	Output	Cables crimped terminal OT	150-10	M10	15Nm
	PE	Cables crimped terminal OT	150-10	M10	15Nm
8-slot	Mains input	Cables crimped terminal OT	240-10	M10	15Nm
	Bypass Input	Cables crimped terminal OT	240-10	M10	15Nm
	Battery Input	Cables crimped terminal OT	240-10	M10	15Nm

	Output	Cables crimped terminal	OT	240-10	M10	15Nm
	PE	Cables crimped terminal	OT	240-10	M10	15Nm

3.8.3. Circuit Breaker

The circuit breakers (CB) for the system are recommended in Table 3-4.

Table 3-4 Recommended CB

Installed position	6-slot cabinet	8-slot cabinet
Main input CB	250A /3P	400A/3P
Bypass input CB	250A/3P	400A/3P
Output CB	250A /3P	400A/3P
Manual Bypass CB	250A /3P	400A/3P
Battery CB	400A DC	630A DC



Attention

The CB with RCD (Residual Current Device) is not suggested for the system

3.8.4. Connecting Power Cables

The steps of connecting power cables are as follows:

- 1) Verify that all the switches of the UPS are completely open and the UPS internal maintenance bypass switch is opened. Attach necessary warning signs to these switches to prevent unauthorized operation.
- 2) Open the front door of the cabinet (10-slot Cabinet open the back door), remove the plastic cover. The input and output terminal, battery terminal and protective earth terminal are shown in Figure 3-15:

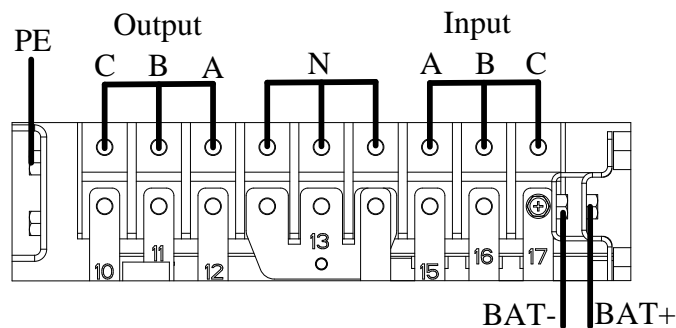

(a) Connections terminals of 6-slot cabinet

single AC input connection

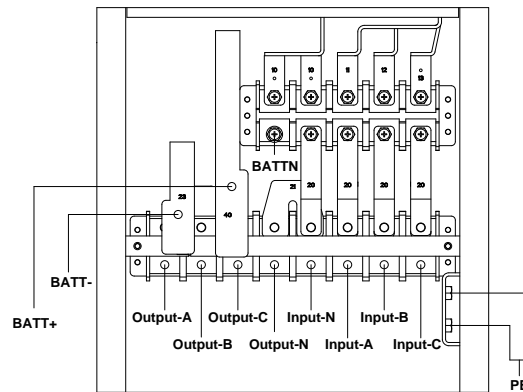

(b) Connections terminals of 8-slot cabinet

split AC input connection

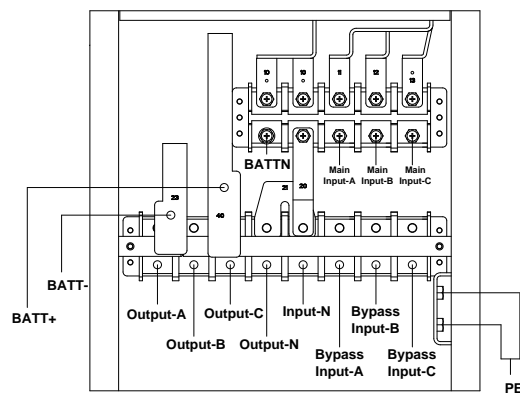

(c) Connections terminals of 2-slot cabinet (dual input)

Figure 3-15 Connections terminals

- 3) Connect the protective earth wire to protective earth terminal (PE).
- 4) Connect the AC input supply cables to the Input terminal and AC output supply cables to the Output terminal. See Figure 3-15
- 5) Connect the Battery cables to the Battery terminal.
- 6) Check to make sure there is no mistake and re-install all the protective covers.



Warning

- Tighten the connections terminals to enough torque moment, refer to 3-3, and please ensure correct phase rotation.
- The grounding cable and neutral cable must be connected in accordance with local and national codes.
- Load must be connected to the same ground as that of UPS system

3.9. Control and Communication Cables

The back panel of the bypass module provides dry contact interface (J2-J11) and communication interface (RS232, RS485, SNMP, SNMP card interface and Parallel interface), as it is shown in Figure 3-16.

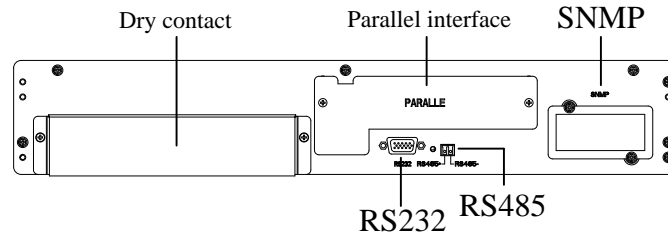

(a) Communication interface of 6-slot cabinet

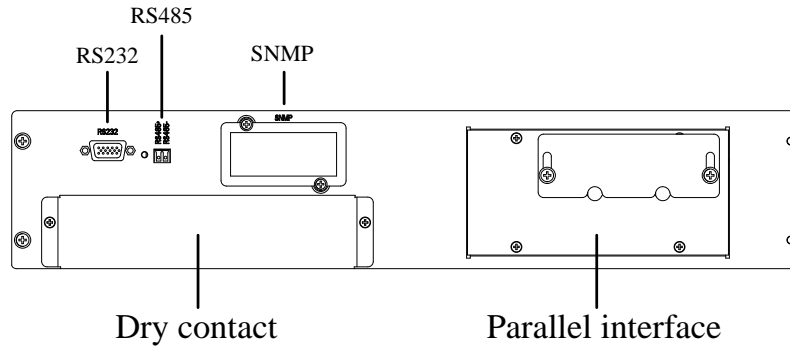

(b) Communication interface of 8-slot cabinet

Figure 3-16 Communication interface

3.9.1. Dry Contact Interface

Dry contact interface includes port J2-J11 and the functions of the dry contact are shown in Table 3-5

Table 3-5 Functions of the port

Port	Name	Function
J2-1	TEMP_BAT	Detection of battery temperature
J2-2	TEMP_COM	Common terminal for temperature detection
J3-1	ENV_TEMP	Detection of environmental temperature
J3-2	TEMP_COM	Common terminal for temperature detection
J4-1	REMOTE_EPO_NC	Trigger EPO when disconnect with J4-2
J4-2	+24V_DRY	+24V
J4-3	+24V_DRY	+24V
J4-4	REMOTE_EPO_NO	Trigger EPO when shorted with J4-3
J5-1	+24V_DRY	+24V
J5-2	GEN_CONNECTED	Input dry contact , function is settable , Default: interface for generator
J5-3	GND_DRY	Ground for +24V
J6-1	BCB Drive	Output dry contact, function is settable. Default: Battery trip signal
J6-2	BCB_Status	Input dry contact, function is settable. Default: BCB Status and BCB Online, (Alert no battery when BCB Status is invalid).
J7-1	GND_DRY	Ground for +24V
J7-2	BCB_Online	Input dry contact, function is settable. Default: BCB Status and BCB Online (Alert no battery

		when BCB Status is invalid).
J8-1	BAT_LOW_ALARM_NC	Output dry contact (Normally closed), function is settable. Default: Low battery alarming
J8-2	BAT_LOW_ALARM_NO	Output dry contact (Normally open), function is settable. Default: Low battery alarming
J8-3	BAT_LOW_ALARM_GND	Common terminal for J8-1 and J8-2
J9-1	GENERAL_ALARM_NC	Output dry contact, (Normally closed) function is settable. Default: Fault alarming
J9-2	GENERAL_ALARM_NO	Output dry contact, (Normally open) function is settable. Default: Fault alarming
J9-3	GENERAL_ALARM_GND	Common terminal for J9-1 and J9-2
J10-1	UTILITY_FAIL_NC	Output dry contact, (Normally closed) function is settable. Default: Utility abnormal alarming
J10-2	UTILITY_FAIL_NO	Output dry contact, (Normally open) function is settable. Default: Utility abnormal alarming
J10-3	UTILITY_FAIL_GND	Common terminal for J10-1 and J10-2

○ **Note**

The settable functions for each port can be set by the monitor software.

The default functions of each port are described as follows.

Battery Warning Output Dry Contact Interface

The input dry contact J2 and J3 can detect the temperature of batteries and environment respectively, which can be used in environment monitoring and battery temperature compensation.

Interfaces diagram for J2 and J3 are shown in Figure 3-17, the description of interface is in Table 3-6.

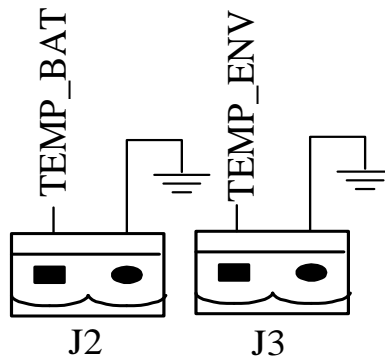

Figure 3-17 J2 and J3 for temperature detecting

Table 3-6 Description of J2 and J3

Port	Name	Function
J2-1	TEMP_BAT	Detection of battery temperature
J2-2	TEMP_COM	common terminal
J3-1	ENV_TEMP	Detection of environmental temperature
J3-2	TEMP_COM	common terminal

○ **Note**

Specified temperature sensor is required for temperature detection (R25=5Kohm, B25/50=3275), please confirm with the manufacturer, or contact the local maintenance engineers when placing an order.

Remote EPO Input Port

J4 is the input port for remote EPO. It requires shorting NC and +24V and disconnecting NO and +24V during normal operation, and the EPO is triggered when opening NC and +24V or shorting the NO and +24V. The port diagram is shown in Figure 3-18 and port description is shown in Table 3-7.

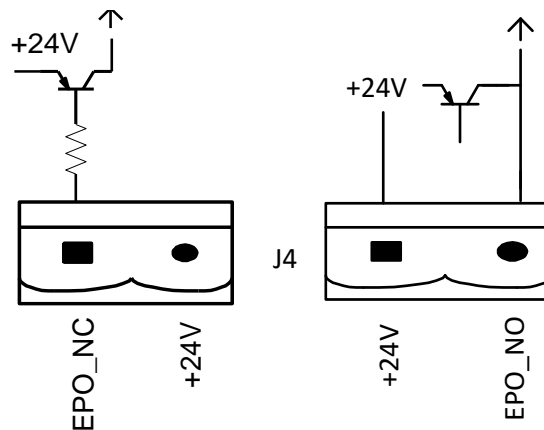

Figure 3-18 Diagram of input port for remote EPO

Table 3-7 Description of input port for remote EPO

Port	Name	Function
J4-1	REMOTE_EPO_NC	Trigger EPO when disconnect with J4-2
J4-2	+24V_DRY	+24V
J4-3	+24V_DRY	+24V
J4-4	REMOTE_EPO_NO	Trigger EPO when connect with J4-3

UPS system in normal operation, port J4-2 to J4-1 should short circuit, and J4-3 to J4-4 should be open.

Generator Input Dry Contact

The default function of J5 is the interface for generator J5. Connect pin 2 of J5 with +24V power supply; it indicates that the generator has been connected with the system. The interface diagram is shown in Figure 2-19, and interface description is shown in Table 3-8.

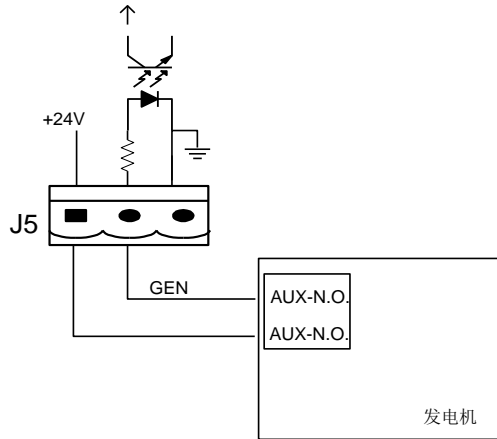

Figure 3-19 Diagram of status interface and connection of generator

Table 3-8 Description of status interface and connection of generator

Port	Name	Function
J5-1	+24V_DRY	+24V
J5-2	GEN_CONNECTED	Connection status of generator
J5-3	GND_DRY	Power ground for +24V

BCB Input Port

The default function of J6 and J7 are the ports of BCB. The port diagram is shown in Figure 3-20, and description is shown in Table 3-9.

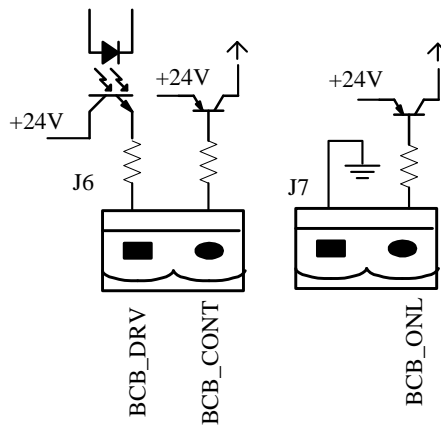

Figure 3-20 BCB Port

Table 3-9 Description of BCB port

Port	Name	Function
J6-1	BCB_DRIV	BCB contact drive, provides +24V voltage, 20mA drive signal
J6-2	BCB_Status	BCB contact status, connect with the normally open signal of BCB
J7-1	GND_DRY	Power ground for +24V
J7-2	BCB_Online	BCB on-line input (normally open) , BCB is on-line when the signal is connecting with J7-1

Battery Warning Output Dry Contact Interface

The default function of J8 is the output dry contact interface, which presents the battery warnings of low or excessive voltage, when the battery voltage is lower than set value, an auxiliary dry contact signal will be activated via the isolation of a relay. The interface diagram is shown in Figure 3-21, and description is shown in Table 3-10.

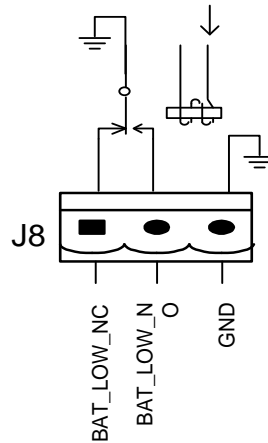

Figure 3-21 Battery warning dry contact interface diagram

Table 3-10 Battery warning dry contact interface description

Port	Name	Function
J8-1	BAT_LOW_ALARM_NC	Battery warning relay (normally closed) will be open during warning
J8-2	BAT_LOW_ALARM_NO	Battery warning relay (normally open) will be closed during warning
J8-3	BAT_LOW_ALARM_GND	Common terminal

General Alarm Output Dry Contact Interface

The default function of J9 is the general alarm output dry contact interface. When one or more warnings are triggered, an auxiliary dry contact signal will be active via the isolation of a relay. The interface diagram is shown in Figure 3-22, and description is shown in Table 3-11.

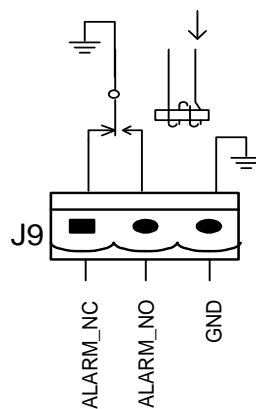

Figure 3-22 Integrated warning dry contact interface diagram

Table 3-11 General alarm dry contact interface description

Port	Name	Function
J9-1	GENERAL_ALARM_NC	Integrated warning relay (normally closed) will be open during warning
J9-2	GENERAL_ALARM_NO	Integrated warning relay (normally open) will be closed during warning
J9-3	GENERAL_ALARM_GND	Common terminal

Utility Fail Warning Output Dry Contact Interface

The default function of J10 is the output dry contact interface for utility failure warning, when the utility fails, the system will send a utility failure warning information, and provide an auxiliary dry contact signal via the isolation of a relay. The interface diagram is shown in Figure 3-23, and description is shown in Table 3-12.

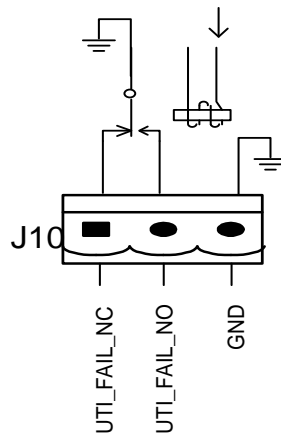

Figure 3-23 Utility failure warning dry contact interface diagram

Table 3-12 Utility failure warning dry contact interface description

Port	Name	Function
J10-1	UTILITY_FAIL_NC	Mains failure warning relay (normally closed) will be open during warning
J10-2	UTILITY_FAIL_NO	Mains failure warning relay (normally open) will be closed during warning
J10-3	UTILITY_FAIL_GND	Common terminal

3.9.2. Communication Interface

RS232, RS485 and USB port: Provide serial data which can be used for commissioning and maintenance by authorized engineers or can be used for networking or integrated monitoring system in the service room.

SNMP: Used on site installation for communication (Optional).

4. Operator Control and Display Panel

4.1. UPS operator panel

The structure of operator control and display panel for cabinet is shown in Figure 4-1

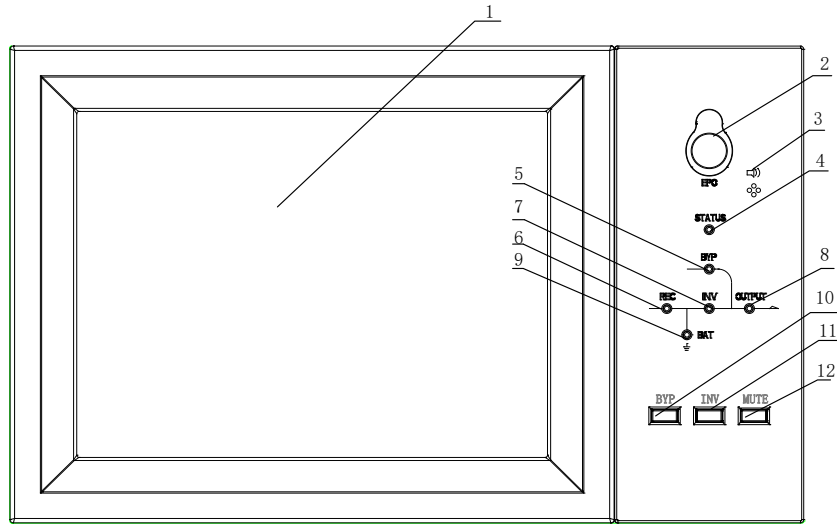

- 1: LCD touch screen 2: EPO switch 3: Audible Alarm (Buzzer)
- 4: Status indicator 5: Bypass indicator 6: Rectifier indicator
- 7: Inverter indicator 8: Load indicator 9: Battery indicator
- 10: Bypass transfer 11: Inverter transfer 12: Mute

Figure 4-1 Control and display panel

4.1.1. LED Indicator

There are 6 LEDs on the panel to indicate the operating status and fault. The description of indicators is shown in 4-1.

4-1 Status description of indicator

Indicator	State	Description
Rectifier indicator	Steady green	Rectifier normal for all modules
	Flashing green	Rectifier normal for at least one module, mains normal
	Steady red	Rectifier fault
	Flashing red	Mains abnormal for at least one module
	Off	Rectifier not operating

Indicator	State	Description
Battery indicator	Steady green	Battery charging
	Flashing green	Battery discharging
	Steady red	Battery abnormal (battery failure, no battery or battery reversed) or battery converter abnormal (failure, over current or over temperature) , EOD
	Flashing red	Battery low voltage
	Off	Battery and battery converter normal, battery not charging
Bypass indicator	Steady green	Load supplied by bypass
	Steady red	Bypass abnormal or out of normal range, or static bypass switch fault
	Flashing red	Bypass voltage abnormal
	Off	Bypass normal
Inverter indicator	Steady green	Load supplied by inverter
	Flashing green	Inverter on, start, synchronization or standby (ECO mode) for at least one module
	Steady red	System output not supplied by inverter, inverter fault for at least one module.
	Flashing red	System output supplied by inverter, inverter fault for at least one module.
	Off	Inverter not operating for all modules
Load indicator	Steady green	UPS output ON and normal
	Steady red	UPS overload time is out, or output short, or output no power supply
	Flashing red	Overload output of UPS
	Off	No output of UPS
Status indicator	Steady green	Normal operation
	Steady red	Failure

There are two different types of audible alarm during UPS operation, as shown in Table 4-2.

Table 4-2 Description of audible alarm

Alarm	Description
Two short alarm with a long one	when system has general alarm (for example: AC fault),
Continuous alarm	When system has serious faults (for example: fuse blown or hardware failure)

4.1.2. Control operation key

Control and operation keys include four keys of 2, 10, 11 and 12, which are used together with LCD touch screen. The functions description is shown in Table 4-3

Table 4-3 Functions of Control and operation keys

Function Key	Description
EPO	Long press, cut off the load power (shut down the rectifier, inverter, static bypass and battery)
BYP	Long press, transfer to the bypass
INV	Long press, transfer to the inverter
MUTE	Long press to switch between turning off and on the buzzing

4.1.3. LCD touch Screen

After the monitoring system starts self-test, the system enters the home page, following the welcome window. The home page is shown in Figure 4-2

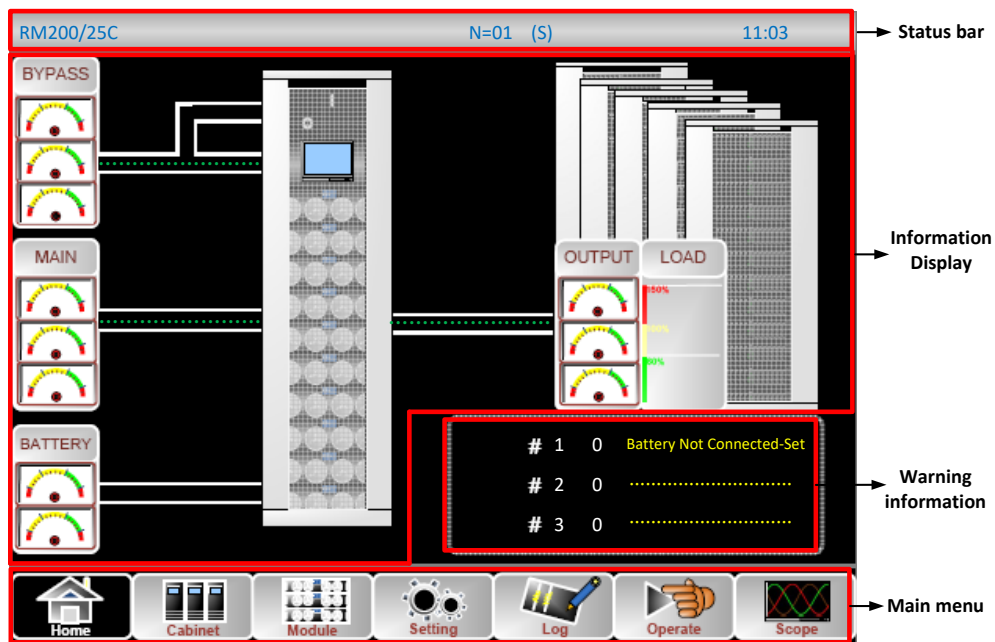

Figure 4-2 Home page

Home page consists of Status bar, Information display, warning information and main menu.

- **Status bar**

The Status bar contains the model of the product, capacity, operational mode, and the number of the power module and the time of the system.

- **Warning Information**

Display the warning information of the cabinet.

- **Information Display**

Users can check the information of the cabinet in this area.

The bypass voltage, main input voltage, battery voltage, and output voltages are presented in the form of gauge.

The loads are displayed in the form of bar chart in percentage. The green area stands for a load of less

than 60%, yellow area for a load of 60%-100% and red area for a load of more than 100%.

The energy flow mimics the flow of the power.

● **Main Menu**

The main menu includes Cabinet, Power m, setting, log, Operate and Scope. Users can operate and control the UPS, and browse all measured parameters through main menu.

The structure of the main menu tree is shown in Figure 4-3

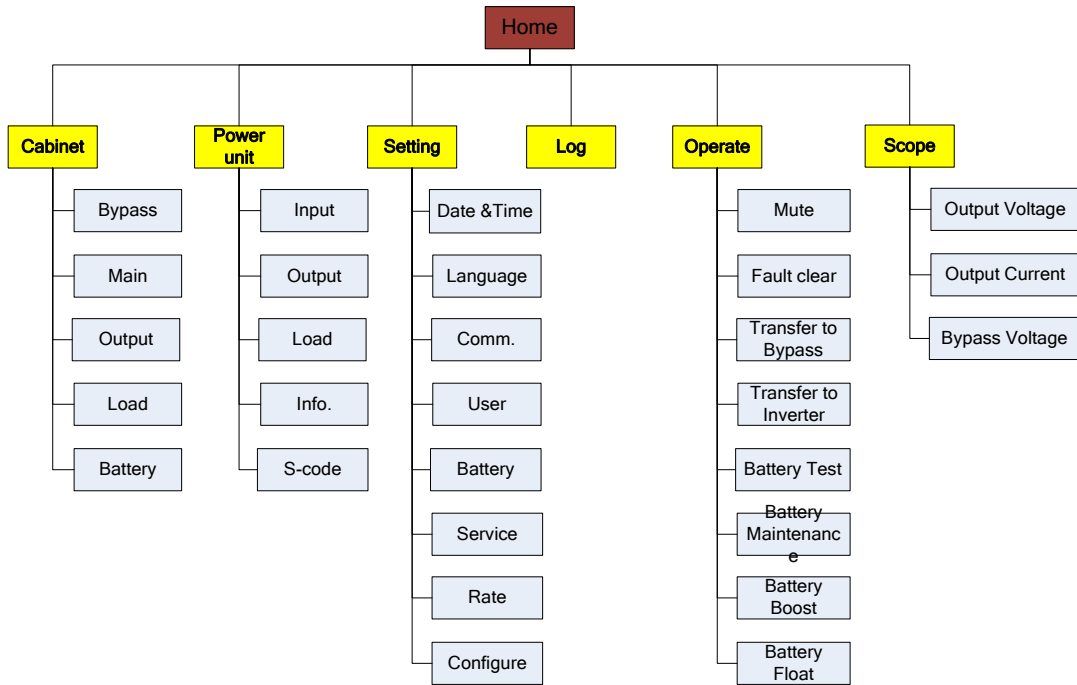



Figure 4-3 Structure of menu tree

4.2 Main Menu

The main menu includes Cabinet, Power module, Setting, Log, Operate and Scope and it is described in details below.

4.2.1 Cabinet

Touch the icon , (At the bottom left of the screen), and the system enters the page of the Cabinet, as it is shown in Figure 4-4

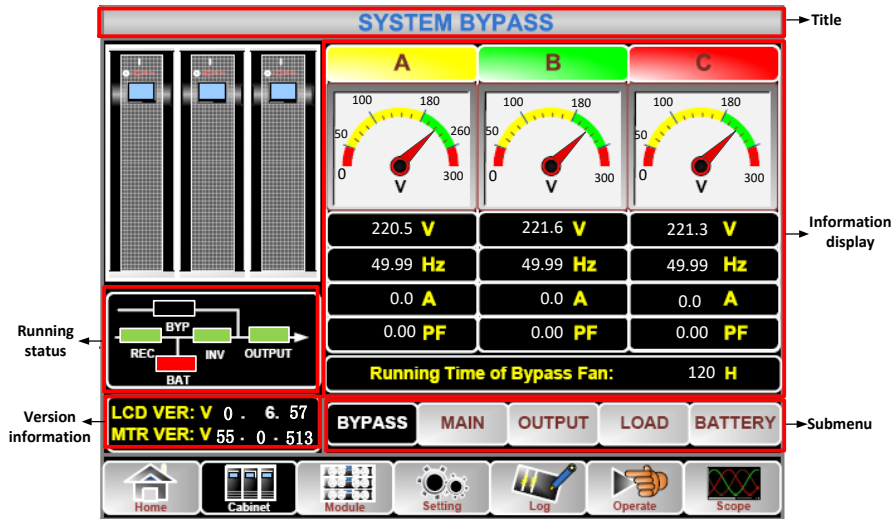
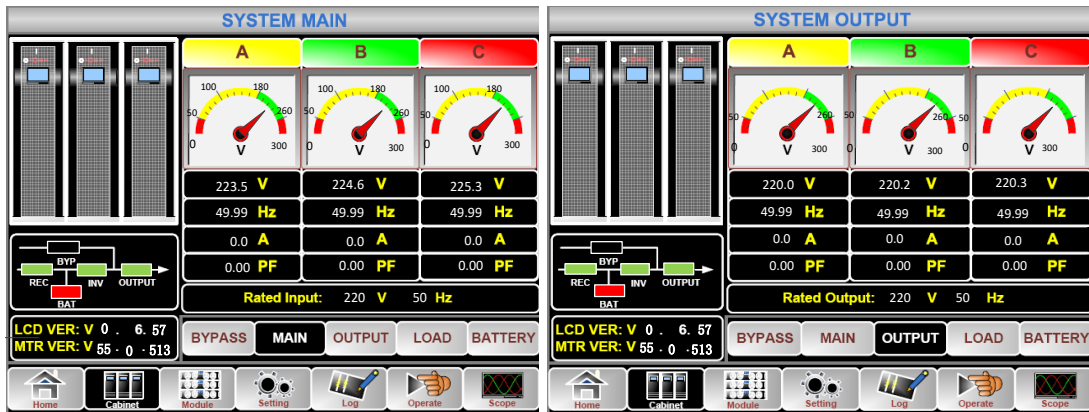

Figure 4-4 Cabinet

The Cabinet comprises sectors of title, information display, version running status, information display and submenu. The sectors are described as follows.

- **Title**
Display the information of the selected submenu.
- **Running status**
The squares shown on the mini current path represent the various UPS power paths and show the current UPS operating status. (The green square indicating the block working normally, the white indicating the absent of the block and red indicating the absence of the block or in fault).
- **Version Information**
The version information for LCD of the cabinet and monitor.
- **Submenu**
It includes the submenu of Bypass, Main, Output, load and battery.
- **Information display**
Display information of each submenu.

The interface of each submenu is shown in Figure.



(a) Interface of Main

(b) Interface of Output

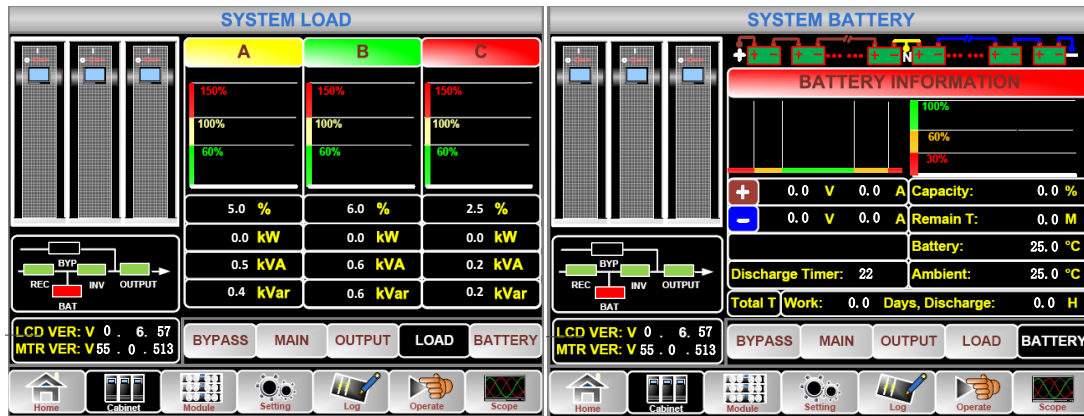

(d) Interface of Load

(d) Interface of Battery

Figure4-5 Submenu interface of Cabinet

The submenu of Cabinet is described in details below in Table 4-4

Table 4-4 Description of each submenu of Cabinet

Submenu Name	Contents	Meaning
Main	V	Phase voltage
	A	Phase current
	Hz	Input frequency
	PF	Power factor
Bypass	V	Phase voltage
	A	Phase current
	Hz	Bypass frequency
	PF	Power factor
Output	V	Phase voltage
	A	Phase current
	Hz	Output frequency
	PF	Power factor
Load	kVA	Sout: Apparent Power
	kW	Pout: Active Power
	kVar	Qout: Reactive power
	%	Load (The percentage of the UPS load)
Battery	V	Battery positive/negative Voltage
	A	Battery positive/negative Current
	Capacity (%)	The percentage compared with new battery capacity
	Remain T (Min)	Remaining battery backup time
	Battery(°C)	Battery Temp
	Ambient(°C)	Environmental Temp
	Total Work T	Total work time
Total Discharge T	Total discharging time	

4.2.2 Power module

Touch the icon  (At the bottom left of the screen), and the system enters the page of the Power unit, as is shown in Figure.

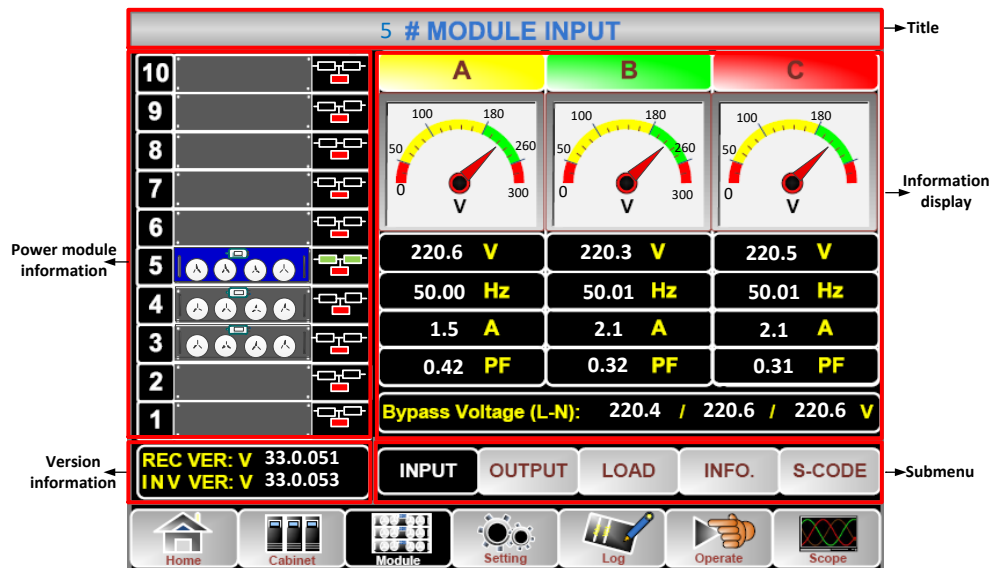

Figure 4-6 Power module

The module comprises sectors of title, information display, power module information, version information and submenu. The sectors are described as follows.

- **Title**

Present the title of submenu of the selected power module.

- **Information display**

Display information of each submenu.

- **Power module information**

The users can choose the power module to browse the information in the "Information display" sector. Colors of the square on the mimic current path represent the various power module paths and show the current operating status.

(a) The green square indicating the power module working normally,

(b) The black indicating power module in invalid

(c) The red indicating the absence of the power module or in fault

Take the 5#power module  for example. It indicates that UPS is in Normal mode and the rectifier and inverter are working normally. The battery is not connected.

- **Version Information**

The version information for rectifier and inverter of the selected power module.

- **Submenu**

The submenu includes Input, Output, Load, INFO and S-CODE.

Users can enter the interface of each submenu by directly touching the icon. Each interface of the submenu is shown in Figure.

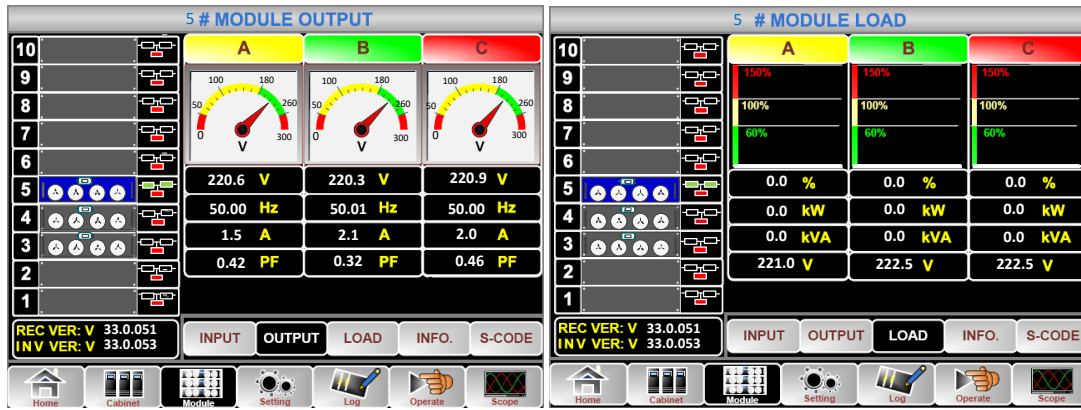

(a) Interface of Output

(b) Interface of Load



(c) Interface of Information

(d) Interface of S-Code

Figure4-7 Module menu

The submenus of Power module are described below in details in Table .

Table 4-5 Description of each submenu of Power module

Submenu Name	Contents	Meaning
Input	V	Input phase voltage of selected module
	A	Input phase current of selected module
	Hz	Input frequency of selected module
	PF	Input power factor of selected module
Output	V	Output phase voltage of selected module
	A	Output phase current of selected module
	Hz	Output frequency of selected module
	PF	Output power factor of selected module
Load	V	Load voltage of selected module
	%	Load (The percentage of the power module selected)
	KW	Pout: Active Power
	KVA	Sout: Apparent Power
Information	BATT+(V)	Battery Voltage (positive)
	BATT-(V)	Battery Voltage (negative)
	BUS(V)	Bus Voltage(Positive &Negative)

Submenu Name	Contents	Meaning
	Charger(V)	Charger Voltage(Positive & Negative)
	Fan Time	Total Fan's Running time of the selected power module
	Inlet Temperature(°C)	Inlet Temperature of the selected power module
	Outlet Temperature(°C)	Outlet Temperature of the selected power module
S-code	Fault Code	For the maintenance personnel

4.2.3 Setting

Touch the icon , (At the bottom of the screen), and the system enters the page of the Setting, as it is shown in Figure.

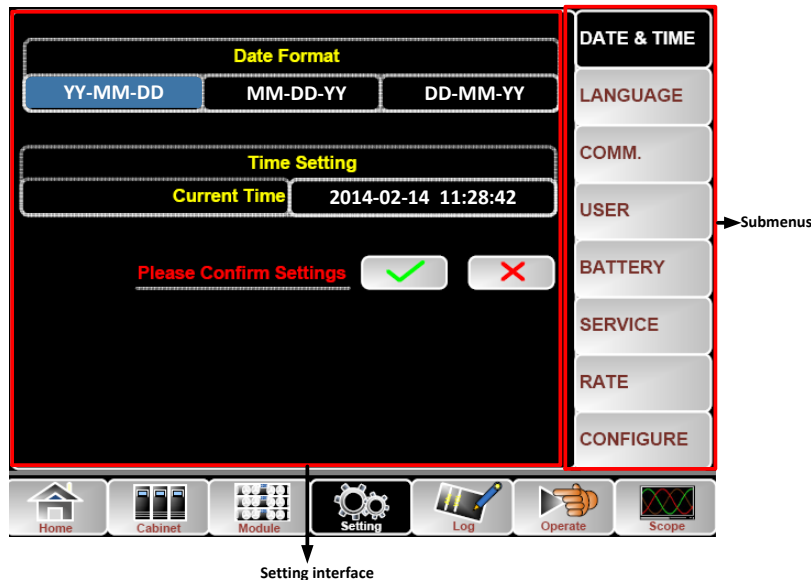

Figure4-8 Setting menu

The submenus are listed on the right side of the Setting page. Users can enter each of the setting interfaces by touching the relevant icon. The submenus are described in details below in Table .

Table 4-6 Description of each submenu of Setting

Submenu Name	Contents	Meaning
Date & Time	Date format setting	Three formats: (a) year/month/day,(b) month/date/year, (c) date/month/year
	Time setting	Setting time
Language	Current language	Language in use
	Language selection	Simplified Chinese and English selectable (The setting taking action immediately after touching the language icon)

Submenu Name	Contents	Meaning
COMM.	Device Address	Setting the communication address
	RS232 Protocol Selection	SNT Protocol, Modbus Protocol, YD/T Protocol and Dwin (For factory use)
	Baud rate	Setting the baud rate of SNT, Modbus and YD/T
	Modbus Mode	Setting mode for Modbus: ASCII and RTU selectable
	Modbus parity	Setting the parity for Modbus
USER	Output voltage Adjustment	Setting the Output Voltage
	Bypass Voltage Up Limited	Up limited working Voltage for Bypass, settable:+10%, +15%, +20%, +25%
	Bypass Voltage Down Limited	Down limited working Voltage for Bypass, settable:-10%, -15%, -20%, -30%, -40%
	Bypass Frequency Limited	Permitted working Frequency for Bypass Settable: +-1Hz, +-3Hz, +-5Hz
	Dust Filter Maintenance Period	Setting Dust Filter Maintenance Period
BATTERY	Battery Number	Setting the number of the battery (12V)
	Battery Capacity	Setting of the AH of the battery
	Float Charge Voltage/Cell	Setting the floating Voltage for battery cell (2V)
	Boost Charge Voltage/Cell	Setting the boost Voltage for battery cell (2V)
	EOD(End of discharge) Voltage/Cell,@0.6C Current	EOD voltage for cell battery,@0.6C current
	EOD(End of charge) Voltage/Cell,@0.15C Current	EOD voltage for cell battery,@0.15C current
	Charge Current Percent Limit	Charge current (percentage of the rated current)
	Battery Temperature Compensate	Coefficient for battery temperature compensation
	Boost Charge Time Limit	Setting boost charging time
	Auto Boost Period	Setting the auto boost period
	Auto Maintenance Discharge Period	Setting the period for auto maintenance discharge
SERVICE	System Mode	Setting the system mode: Single , parallel, Single ECO, parallel ECO, LBS, parallel LBS

Submenu Name	Contents	Meaning
RATE	Configure the rated Parameter	For the factory use
CONFIGURE	Configure the system	For the factory use

- **Note**
- Users have various permissions to the configuration of the Setting :(a) for the Date &Time, LANGUAGE and COMM, user can set on their own without password. (b)For the USER, a one-level password is needed and the setting must be done by commissioning engineer (c) For the Battery and SERVICE, a Two-level password is needed and it is set by the after-service personal. (d)For the RATE and CONFIGURE, a Three-level password is needed and it is set only by the factory.
- The “C” stands for Ampere number. For instance, if the battery is 100AH, then C=100A.



Warning

Ensure the number of the battery, set via the menu or the monitoring software, is completely equal to the real installed number. Otherwise it will cause serious damage to the batteries or the equipment.

4.2.4 Log

Touch the icon , (At the bottom of the screen), and the system enters the interface of the Log, as it is shown in Figure 4-9 Log menu. The log is listed in reverse chronological order (i.e. the first on the screen with #1 is the most new), which displays the events, warnings and faults information and the data and time they occur and disappear.

NO.	M# EVENTS	TIME
1	0 # Load On UPS-Set	2014 - 2 - 14 16 :26 : 1
2	4 # Module Inserted-Set	2014 - 2 - 14 16 :24 : 27
3	0 # Byp Freq Over Track-Set	2014 - 2 - 14 16 :22 : 31
4	0 # Load On Bypass-Set	2014 - 2 - 14 16 :21 : 33
5	0 # Bypass Volt Abnormal-Set	2014 - 2 - 14 16 :21 : 33
6	0 # Load On Bypass-Set	2014 - 2 - 14 16 :19 : 41
7	0 # No Load-Set	2014 - 2 - 14 16 :18 : 45
8	4 # Load On Bypass-Set	2014 - 2 - 14 16 :18 : 45
9	0 # Byp Freq Over Track-Set	2014 - 2 - 14 16 :18 : 45
10	4 # Module-Exit-Set	2014 - 2 - 14 16 :26 : 1

Total Log Items 29

Home Cabinet Module Setting Log Operate Scope

Figure 4-9 Log menu

The follow Table 4-7 gives the complete list of all the UPS events displayed by history record window and current record window.

Table 4-7 UPS Event List

NO.	UPS events	Description
1	Fault Clear	Manually clear fault
2	Log Clear	Manually clear History log
3	Load On UPS	Inverter feeds load
4	Load On Bypass	Bypass feeds load
5	No Load	No load
6	Battery Boost	Charger is working in boost charging mode
7	Battery Float	Charger is working in float charging mode
8	Battery Discharge	Battery is discharging
9	Battery Connected	Battery is connected already
10	Battery Not Connected	Battery is not yet connected.
11	Maintenance CB Closed	Manual maintenance breaker is closed
12	Maintenance CB Open	Manual maintenance breaker is opened
13	EPO	Emergency Power Off
14	Module On Less	Available power module capacity is less than the load capacity. Please reduce the load capacity or add extra power module to make sure that the UPS capacity is big enough.
15	Generator Input	Generator is connected and a signal is sent to the UPS.
16	Utility Abnormal	Utility (Grid) is abnormal. Mains voltage or frequency exceeds the upper or lower limit and results in rectifier shutdown. Check the input phase voltage of rectifier.
17	Bypass Sequence Error	Bypass voltage Sequence is reverse. Check if input power cables are connected correctly.
18	Bypass Voltage Abnormal	<p>This alarm is triggered by an inverter software routine when the amplitude or frequency of bypass voltage exceeds the limit. The alarm will automatically reset if the bypass voltage becomes normal.</p> <p>First check if relevant alarm exists, such as "bypass circuit breaker open", "Byp Sequence Err" and "Ip Neutral Lost". If there is any relevant alarm, first clear this alarm.</p> <ol style="list-style-type: none"> 1. Then check and confirm if the bypass voltage and frequency displayed on the LCD are within the setting range. Note that the rated voltage and frequency are respectively specified by "Output Voltage" and "Output Frequency". 2. If the displayed voltage is abnormal, measure the actual bypass voltage and frequency. If the measurement is abnormal, check the external bypass power supply. If the alarm occurs frequently, use the configuration software to increase the bypass high limit set point according to the user's suggestions
19	Bypass Module Fail	Bypass Module Fails. This fault is locked until power off. Or bypass fans fail.
20	Bypass Module Over Load	Bypass current is over the limitation. If bypass current is under 135% of the rated current. The UPS alarms but has no action.
21	Bypass Over Load Tout	The bypass overload status continues and the overload times out.
22	Byp Freq Over Track	This alarm is triggered by an inverter software routine when the frequency of bypass voltage exceeds the limit. The alarm will automatically reset if the bypass voltage becomes normal.

		<p>First check if relevant alarm exists, such as “bypass circuit breaker open”, “By Sequence Err” and “Ip Neutral Lost”. If there is any relevant alarm, first clear this alarm.</p> <ol style="list-style-type: none"> 1. Then check and confirm if the bypass frequency displayed on the LCD are within the setting range. Note that the rated frequency are respectively specified by “Output Frequency”. 2. If the displayed voltage is abnormal, measure the actual bypass frequency. If the measurement is abnormal, check the external bypass power supply. If the alarm occurs frequently, use the configuration software to increase the bypass high limit set point according to the user’s suggestions
23	Exceed Tx Times Lmt	The load is on bypass because the output overload transfer and re-transfer is fixed to the set times during the current hour. The system can recover automatically and will transfer back to the inverter with 1 hour
24	Output Circuit Short	<p>Output shorted Circuit.</p> <p>Fist check and confirm if loads have something wrong.</p> <p>Then check and confirm if there is something wrong with terminals, sockets or some other power distribution unit.</p> <p>If the fault is solved, press “Fault Clear” to restart UPS.</p>
25	Battery EOD	Inverter turned off due to low battery voltage. Check the mains power failure status and recover the mains power in time
26	Battery Test	System transfer to battery mode for 20 seconds to check if batteries are normal
27	Battery Test OK	Battery Test OK
28	Battery Maintenance	System transfer to battery mode until to be 1.1*EOD voltage to maintenance battery string
29	Battery Maintenance OK	Battery maintenance succeed
30	Module inserted	Power Module is inserted in system.
31	Module Exit	Power Module is pulled out from system.
32	Rectifier Fail	The N# Power Module Rectifier Fail, The rectifier is fault and results in rectifier shutdown and battery discharging.
33	Inverter Fail	The N# Power Module Inverter Fail. The inverter output voltage is abnormal and the load transfers to bypass.
34	Rectifier Over Temp.	<p>The N# Power Module Rectifier Over Temperature. The temperature of the rectifier IGBTs is too high to keep rectifier running. This alarm is triggered by the signal from the temperature monitoring device mounted in the rectifier IGBTs. The UPS recovers automatically after the over temperature signal disappears.</p> <p>If over temperature exists, check:</p> <ol style="list-style-type: none"> 1. Whether the ambient temperature is too high. 2. Whether the ventilation channel is blocked. 3. Whether fan fault happens. 4. Whether the input voltage is too low.
35	Fan Fail	At least one fan fails in the N# power module.
36	Output Over load	<p>The N# Power Module Output Over Load. This alarm appears when the load rises above 100% of nominal rating. The alarm automatically resets once the overload condition is removed.</p> <ol style="list-style-type: none"> 1. Check which phase has overload through the load (%) displayed in LCD so as to confirm if this alarm is true. 2. If this alarm is true, measure the actual output current to confirm if the displayed value is correct.

		Disconnect non-critical load. In parallel system, this alarm will be triggered if the load is severely imbalanced.
37	Inverter Overload Tout	<p>N# Power Module Inverter Over Load Timeout. The UPS overload status continues and the overload times out.</p> <p>Note:</p> <p>The highest loaded phase will indicate overload timing-out first. When the timer is active, then the alarm "module over load" should also be active as the load is above nominal.</p> <p>When the time has expired, the inverter Switch is opened and the load transferred to bypass.</p> <p>If the load decreases to lower than 95%, after 2 minutes, the system will transfer back to inverter mode. Check the load (%) displayed in LCD so as to confirm if this alarm is true. If LCD displays that overload happens, then check the actual load and confirm if the UPS has over load before alarm happens.</p>
38	Inverter Over Temp.	<p>The N# Power Module Inverter Over Temperature.</p> <p>The temperature of the inverter heat sink is too high to keep inverter running. This alarm is triggered by the signal from the temperature monitoring device mounted in the inverter IGBTs. The UPS recovers automatically after the over temperature signal disappears.</p> <p>If over temperature exists, check:</p> <p>Whether the ambient temperature is too high.</p> <p>Whether the ventilation channel is blocked.</p> <p>Whether fan fault happens.</p> <p>Whether inverter overload time is out.</p>
39	On UPS Inhibited	<p>Inhibit system transfer from bypass to UPS (inverter). Check:</p> <p>Whether the power module's capacity is big enough for load.</p> <p>Whether the rectifier is ready.</p> <p>Whether the bypass voltage is normal.</p>
40	Manual Transfer Byp	Transfer to bypass manually
41	Esc Manual Bypass	Escape from "transfer to bypass manually" command. If UPS has been transferred to bypass manually, this command enable UPS to transfer to inverter.
42	Battery Volt Low	Battery Voltage is Low. Before the end of discharging, battery voltage is low warning should occur. After this pre-warning, battery should have the capacity for 3 minutes discharging with full load.
43	Battery Reverse	Battery cables are connected not correctly.
44	Inverter Protect	<p>The N# Power Module Inverter Protect. Check:</p> <p>Whether inverter voltage is abnormal</p> <p>Whether inverter voltage is much different from other modules, if yes, please adjust inverter voltage of the power module separately.</p>
45	Input Neutral Lost	The mains neutral wire is lost or not detected. For 3 phases UPS, it's recommended that user use a 3-poles breaker or switch between input power and UPS.
46	Bypass Fan Fail	At least one of bypass module Fans Fails
47	Manual Shutdown	The N# Power Module is manually shutdown. The power module shuts down rectifier and inverter, and there's on inverter output.
48	Manual Boost Charge	Manually force the Charger work in boost charge mode.
49	Manual Float Charge	Manually force the charger work in float charge mode.
50	UPS Locked	Forbidden to shutdown UPS power module manually.

51	Parallel Cable Error	Parallel cables error. Check: If one or more parallel cables are disconnected or not connected correctly If parallel cable round is disconnected If parallel cable is OK
53	Lost N+X Redundant	Lost N+X Redundant. There is no X redundant powers module in system.
54	EOD Sys Inhibited	System is inhibited to supply after the battery is EOD (end of discharging)
55	Battery Test Fail	Battery Test Fail. Check if UPS is normal and battery voltage is over 90% of float voltage.
56	Battery Maintenance Fail	Check If UPS is normal and not any alarms If the battery voltage is over 90% of float voltage If load is over 25%
57	Ambient Over Temp	Ambient temperature is over the limit of UPS. Air conditioners are required to regulate ambient temperature.
58	REC CAN Fail	Rectifier CAN bus communication is abnormal. Please check if communication cables are not connected correctly.
59	INV IO CAN Fail	IO signal communication of inverter CAN bus is abnormal. Please check if communication cables are not connected correctly.
60	INV DATA CAN Fail	DATA communication of inverter CAN bus is abnormal. Please check if communication cables are not connected correctly.
61	Power Share Fail	The difference of two or more power modules' output current in system is over limitation. Please adjust output voltage of power modules and restart UPS.
62	Sync Pulse Fail	Synchronization signal between modules is abnormal. Please check if communication cables are not connected correctly.
63	Input Volt Detect Fail	Input voltage of N# power module is abnormal. Please check if the input cables are connected correctly. Please check if input fuses are broken. Please check if utility is normal.
64	Battery Volt Detect Fail	Battery voltage is abnormal. Please check if batteries are normal. Please check if battery fuses are broken on input power board.
65	Output Volt Fail	Output voltage is abnormal.
66	Bypass Volt Detect Fail	Bypass voltage is abnormal. Please check if bypass breaker is closed and is good. Please check if bypass cables are connected correctly.
67	INV Bridge Fail	Inverter IGBTs are broken and opened.
68	Outlet Temp Error	Outlet temperature of power module is over the limitation. Please check if fans are abnormal. Please check if PFC or inverter inductors are abnormal. Please check if air passage is blocked. Please check if ambient temperature is too high.
69	Input Curr Unbalance	The difference of input current between every two phases is over 40% of rated current. Please check if rectifier's fuses, diode, IGBT or PFC diodes are broken. Please check if input voltage is abnormal.
70	DC Bus Over Volt	Voltage of DC bus capacitors is over limitation. UPS shutdown rectifier and inverter.
71	REC Soft Start Fail	While soft start procedures are finished, DC bus voltage is lower than the limitation of calculation according utility voltage. Please check

		<ol style="list-style-type: none"> 1. Whether rectifier diodes are broken 2. Whether PFC IGBTs are broken 3. Whether PFC diodes are broken 4. Whether drivers of SCR or IGBT are abnormal 5. Whether soft start resistors or relay are abnormal
72	Relay Connect Fail	Inverter relays are opened and cannot work or fuses are broken.
73	Relay Short Circuit	Inverter relays are shorted and cannot be released.
74	PWM Sync Fail	PWM synchronizing signal is abnormal
75	Intelligent Sleep	UPS works in intelligent sleep mode. In this mode, the power modules will be standby in turn. It will be more reliability and higher efficiency. It must be confirmed that remained power modules' capacity is big enough to feed load. It must be conformed that working modules' capacity is big enough if user add more load to UPS. It's recommended that sleeping power modules are waken up if the capacity of new added loads is not sure.
76	Manual Transfer to INV	Manually transfer UPS to inverter. It's used to transfer UPS to inverter when bypass is over track. The interrupt time could be over 20ms.
77	Input Over Curr Tout	Input over current timeout and UPS transfer to battery mode. Please check if input voltage is too low and output load is big. Please regulate input voltage to be higher if it's possible or disconnect some loads.
78	No Inlet Temp. Sensor	Inlet temperature sensor is not connected correctly.
79	No Outlet Temp. Sensor	Outlet temperature sensor is not connected correctly.
80	Inlet Over Temp.	Inlet air is over temperature. Make sure that the operation temperature of UPS is between 0-40°C.
81	Capacitor Time Reset	Reset timing of DC bus capacitors.
82	Fan Time Reset	Reset timing of fans.
83	Battery History Reset	Reset battery history data.
84	Byp Fan Time Reset	Reset timing of bypass fans.
85	Battery Over Temp.	Battery is over temperature. It's optional.
86	Bypass Fan Expired	Working life of bypass fans is expired, and it's recommended that the fans are replaced with new fans. It must be activated via software.
87	Capacitor Expired	Working life of capacitors is expired, and it's recommended that the capacitors are replaced with new capacitors. It must be activated via software.
88	Fan Expired	Working life of power modules' fans is expired, and it's recommended that the fans are replaced with new fans. It must be activated via software.
89	INV IGBT Driver Block	Inverter IGBTs are shutdown. Please check if power modules are inserted in cabinet correctly. Please check if fuses between rectifier and inverter are broken.
90	Battery Expired	Working life of batteries is expired, and it's recommended that the batteries are replaced with new batteries. It must be activated via software.
91	Bypass CAN Fail	The CAN bus between bypass module and cabinet is abnormal.
92	Dust Filter Expired	Dust filter need to be clear or replaced with a new one
102	Wave Trigger	Waveform has been saved while UPS fail
103	Bypass CAN Fail	Bypass and cabinet communicate with each other via CAN bus. Check

		If connector or signal cable is abnormal. If monitoring board is abnormal.
105	Firmware Error	Manufacturer used only.
106	System Setting Error	Manufacturer used only.
107	Bypass Over Temp.	Bypass module is over temperature. Please check If bypass load is overload If ambient temperature is over 40°C If bypass SCRs are assembled correctly If bypass fans are normal
108	Module ID Duplicate	At least two modules are set as same ID on the power connector board, please set the ID as correct sequence

○ **Note**

Different colors of the words represent different level of events:

- (a) Green, an event occurs ;
- (b) Grey, the event occurs then clears ;
- (c) Yellow, warning occurs ;
- (d) Red, faults happen.

4.2.5 Operate

Touch the icon  (At the bottom of the screen), and the system enters the page of the "Operate", as it is shown in Figure.

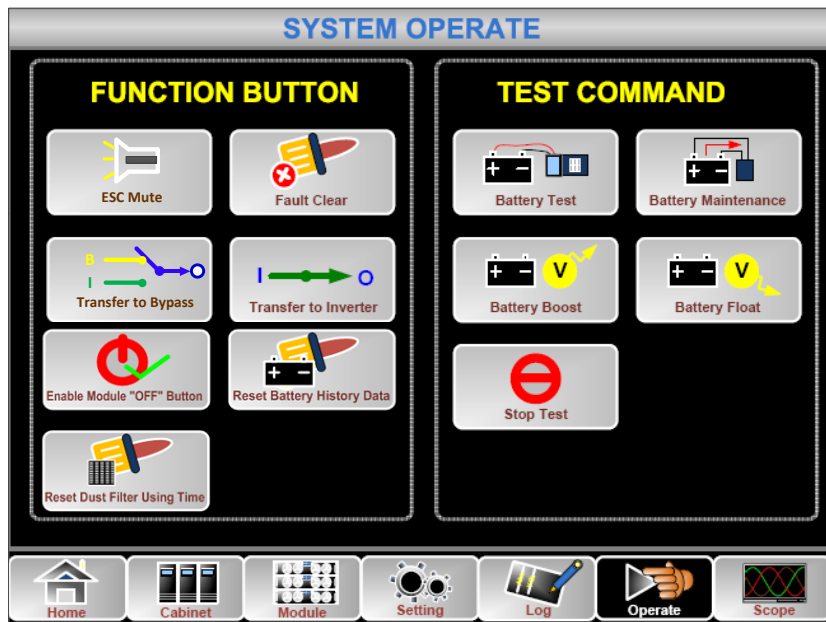



Figure4-10 Operate menu

The "Operate" menu includes FUNCTIONBUTTON and TESTCOMMAND. The contents are described in details below.

FUNCTION BUTTON

- **Clear/Restore Buzzing**

Mute or Restore buzzing of the system by touching the icon  or .

- **Fault Clear**

Clear the faults by touching the icon .

- **Transfer to and ESC Bypass**

Transfer to bypass mode or cancel this command by touching the icon  or .

- **Transfer to Inverter**

Transfer the bypass mode to Inverter Mode by touching the icon .

- **Enable Module "OFF" Button**

Enable the switch for powering off the Power Module by touching the icon .

- **Reset Battery History Data**

Reset the battery history data by touching the icon , the history data includes the times of discharge, days for running and hours of discharging.

- **Reset Dust filter Using Time**

Reset the time of dust filter using by touching the icon , it includes the days of using and maintenance period.

TEST COMMAND

- **Battery Test**

By touching the icon , the system transfer to the Battery mode to test the condition of the battery. Ensure the bypass is working normally and the capacity of the battery is no less than 25%.

- **Battery Maintenance**

By touching the icon , the system transfers to the Battery mode. This function is used for maintaining the battery, which requires the normality of the bypass and minimum capacity of 25% for the battery.

- **Battery Boost**

By touching the icon , the system starts boost charging.

- **Battery Float**

By touching the icon , the system starts float charging.

- **Stop Test**



By touching the icon , the system stops battery test or battery maintenance.

4.2.6 Scope



Touch the icon , (At the bottom right of the screen), and the system enters the page of the Scope, as it is shown in Figure.

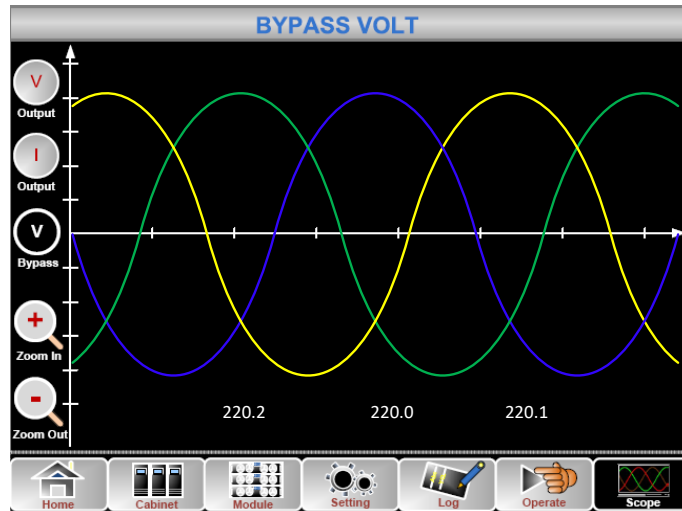





Figure 4-11 Scope Menu

Users can view the waves for output voltage, output current and bypass voltage by touching the corresponding icon in the left side of the interface. The waves can be zoomed in and zoom out.

-  Touch the icon to display the 3 phase output voltage.

-  Touch the icon to display the 3 phase output current.

-  Touch the icon to display the 3 phase bypass voltage.

-  Touch the icon to zoom in the wave.

-  Touch the icon to zoom out wave.

5 Operations

5.1 UPS Start-up

5.1.1 Start in Normal Mode

The UPS must be started up by commissioning engineer after the completeness of installation. The steps below must be followed :

- 1) Ensure all the circuit breakers are open.
- 2) One by one to turn on the output breaker (Q4), input breaker (Q1), bypass input breaker (Q2), and then the system starts initializing (4-slot cabinet and 6-slot cabinet only have a manual bypass breaker, so need to used external circuit breakers).
- 3) The LCD in front of the cabinet is lit up. The system enters the home page, as shown in Figure3-2.
- 4) Notice the energy bar in the home page, and pay attention to the LED indicators. The rectifier flashes indicating the rectifier is starting up. The LED indicators are listed below in Table 5-1.

Table 5-1 Rectifier starting up

Indicator	Status	Indicator	Status
Rectifier	green flashing	Inverter	off
Battery	red	Load	off
Bypass	off	Status	red

- 5) After 30S, the rectifier indicator goes steady green, presenting the finishing of rectification and bypass static switch closes then the inverter is starting up. The LED indicators are listed below in Table 5-2.

Table 5-2 Inverter starting up

Indicator	Status	Indicator	Status
Rectifier	green	Inverter	green flashing
Battery	red	Load	green
Bypass	green	Status	red

- 6) The UPS transfers from the bypass to inverter after the inverter goes normal. The LED indicators are listed below in Table 5-3.

Table 5-3 Supplying the load

Indicator	Status	Indicator	Status
Rectifier	green	Inverter	green
Battery	red	Load	green
Bypass	off	Status	red

- 7) The UPS is in Normal Mode. Close the battery circuit breakers and the UPS starts charging the battery. The LED indicators are listed below in Table 5-4.

Table 5-4 Normal mode

Indicator	Status	Indicator	Status
Rectifier	green	Inverter	green
Battery	green	Load	green
Bypass	off	Status	green

○ **Note**

- When the system starts, the stored setting will be loaded.
- Users can browse all events during the process of the starting up by checking the menu **Log**.
- Users can check the information of the power module by the keys in the front of it.

5.1.2. Start from Battery

The start from battery is referring to battery cold start. The steps for the start-up are as follows :

1. Confirm the battery is correctly connected; ;
2. Turn on the external battery circuit breakers. ;
3. Press the red button for the battery cold start. The system is then powered by the battery. See Figure 5-1

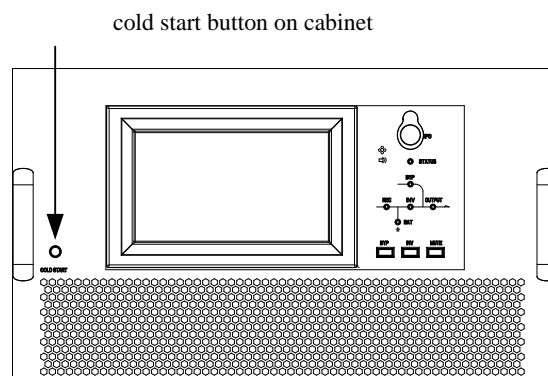

Figure 5-1 the position of the battery cold start button on cabinet

4. Pressed into the cold starting button hole of all the power modules in turns and the power module indicator light are lighted. See Figure 5-2.

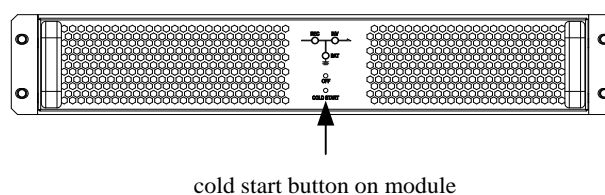

Figure 5-2 the position of the battery cold start button on module

5. After that, the system is starting up and the system transfers to battery mode in 60S
6. Turn on the external output power supply isolation to supply the load, and the system is working on battery model.

○ **Note**

If the LCD monitor is switched off during the cold start, press the cold start button again.

5.2. Procedure for Switching between Operation Modes

5.2.1. Switching the UPS into Battery Mode from Normal Mode

The UPS transfers to Battery model immediately after the utility (mains voltage) is failed or drops down below the predefined limit.

5.2.2. Switching the UPS from Normal Mode into Bypass Mode

Enter the menu Operate, touch the icon “transfer to bypass”  and the system transfers to bypass mode.



Warning

Ensure the bypass is working normally before transferring to bypass mode. Or it may cause failure.

5.2.3. Switching the UPS into Normal Mode from Bypass Mode

Enter the menu Operate, touch the icon transfer to inverter  and the system transfers to bypass mode.

5.2.4. Switching the UPS from Normal Mode into Maintenance Bypass Mode

These following procedures can transfer the load from the UPS inverter output to the maintenance bypass supply, which is used for maintaining.

- 1) Transfer the UPS into Bypass mode following section 5.2.2.
- 2) The inverter indicator LED goes out, status indicator LED goes out, the buzzer alarm, the inverter shutdown. The bypass supplies power to loads.
- 3) Turn off the external battery breaker and turn on the maintenance bypass breaker. And the load is powered through maintenance bypass and static bypass.
- 4) Then pull out bypass module. The maintenance bypass supplies power to loads.

- **Note**

6-slot cabinet does not have a manual bypass breaker. It needs optional PDU.
In manual bypass mode (The manual bypass supplies power to loads), dangerous voltages are present on terminal and internal Copper bar.



Warning

Before making this operation, read messages on LCD display to be sure that bypass supply is regular and the inverter is synchronous with it, so as not to risk a short interruption in powering the load.



Danger

If you need to maintain the power module, wait for 10 minutes to let the DC bus capacitor fully

discharge before removing the cover.

5.2.5. Switching the UPS into Normal Mode from Maintenance Bypass Mode

These following procedures can transfer the load from the Maintenance Bypass to inverter output:

1. Power ON, after 30S, the static bypass turns on, the bypass indicator LED goes green, and the load is powered through maintenance bypass and static bypass ;
2. Turn off the maintenance bypass breaker and the load is powered through static bypass ;
3. After 30S, the rectifier starts, the rectifier indicator LED goes green, and then inverter start. After 60S, the system transfers to Normal mode.

○ **Note**

6-slot cabinet does not have a manual bypass breaker. It needs optional PDU

5.3 Battery Manual

If the battery is not in use for a long time, it is necessary to test the condition of the battery. Two methods are provided:

- 1) Manual Discharging test. Enter the menu Operate, as is shown in Figure and touch the icon

“Battery maintenance”  , the system transfers into the Battery mode for discharging. The system will stop discharging when the battery will have 20% of capacity or in low voltage.

Users can stop the discharging by touching the “Stop Test” icon  .

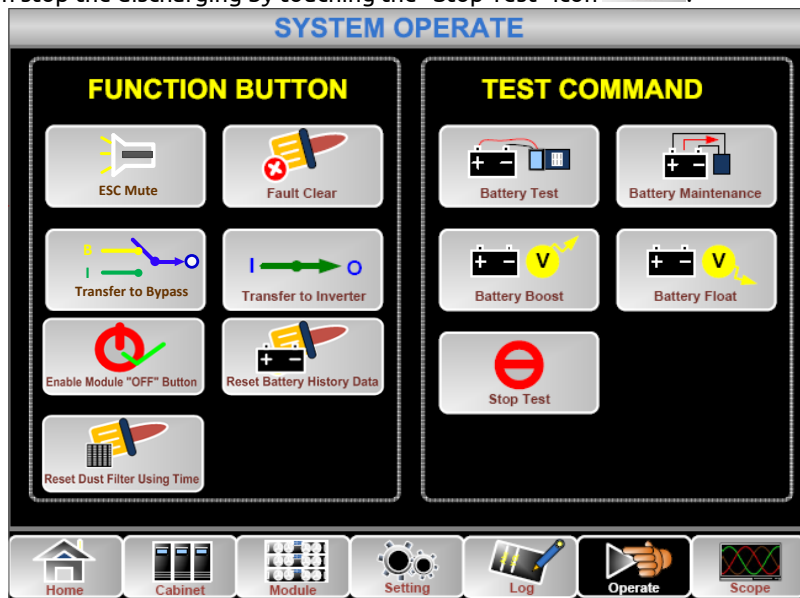

Figure 5-3 Battery maintenance

- 2) Auto discharging. The system can maintain the battery automatically when the setting is done. The setting procedures are as follows.
 - (a) Enable battery auto discharge. Enter the “CONFIGURE” page of the menu Setting, tick the “Battery Auto Discharge” and confirm (This needs to be done by factory).
 - (b) Setting period for battery auto discharge. Enter the “BATTERY” page of the Setting (See

Figure), Set the period time in the item “Auto Maintenance Discharge Period” and confirm.

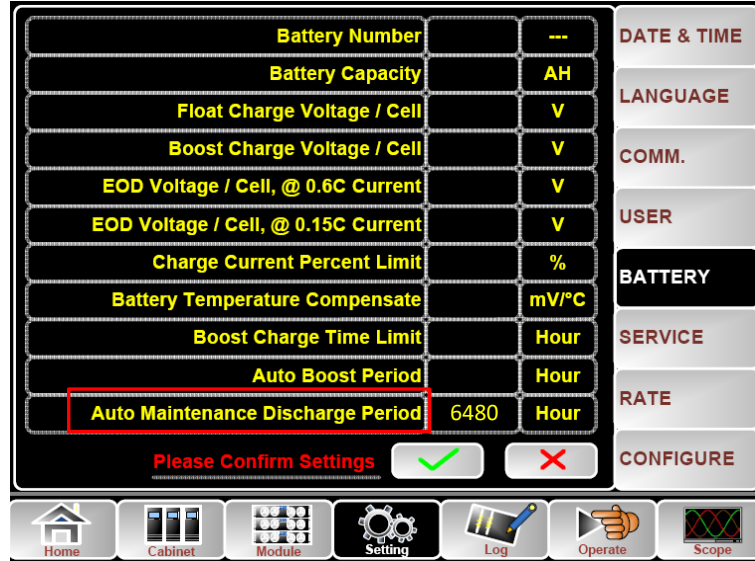

Figure 5-4 Setting period for battery auto discharge

 **Warning**

The load for the auto maintenance discharge should be 20%-100%, if not, the system will not start the process automatically.

5.4 EPO

The EPO button located in the operator control and display panel (with cover to avoid disoperation, see Figure) is designed to switch off the UPS in emergency conditions (e.g., fire, flood, etc.). To achieve this, just press the **EPO** button, and the system will turn off the rectifier, inverter and stop powering the load immediately (including the inverter and bypass), and the battery stops charging or discharging. If the input utility is present, the UPS control circuit will remain active; however, the output will be turned off. To completely isolate the UPS, users need to turn off the external mains input supply to the UPS. Users can restart the UPS by powering the UPS again.

 **Warning**

When the EPO is triggered, the load is not powered by the UPS. Be careful to use the EPO function.

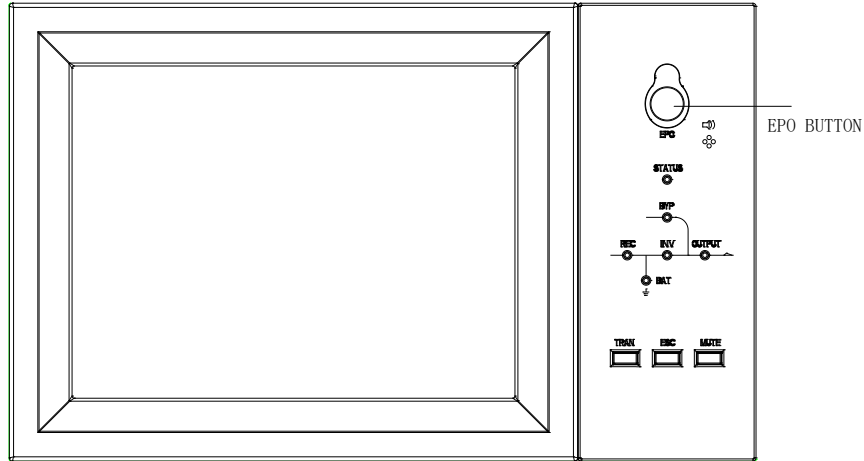

Figure 5-5 EPO Button

5.5 Installation of Parallel Operation System

The UPS system can have three cabinets in parallel.

Two UPS cabinets are connected as is shown in Figure .

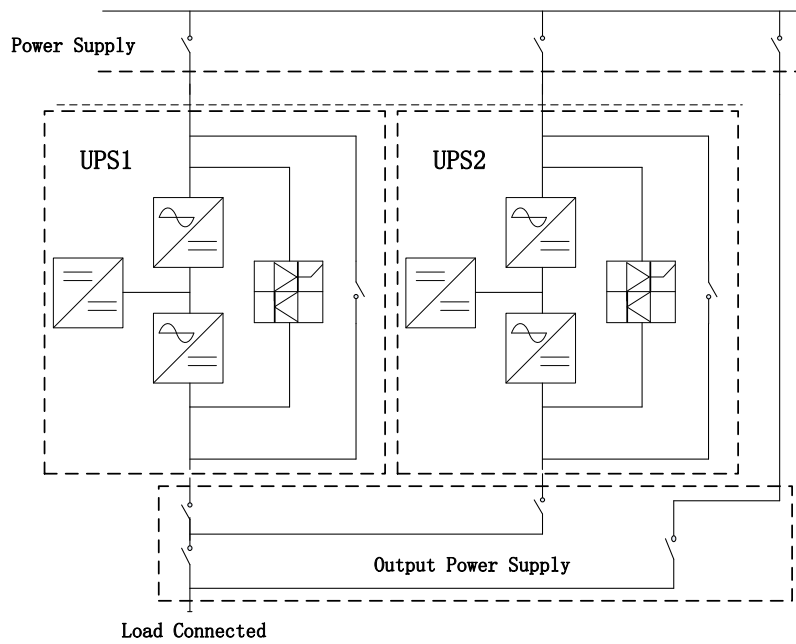
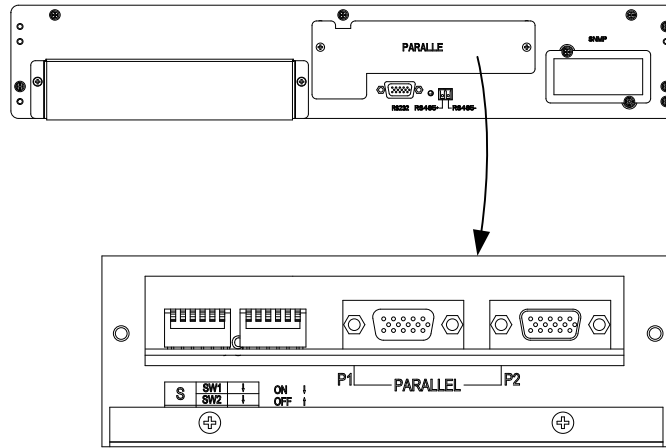
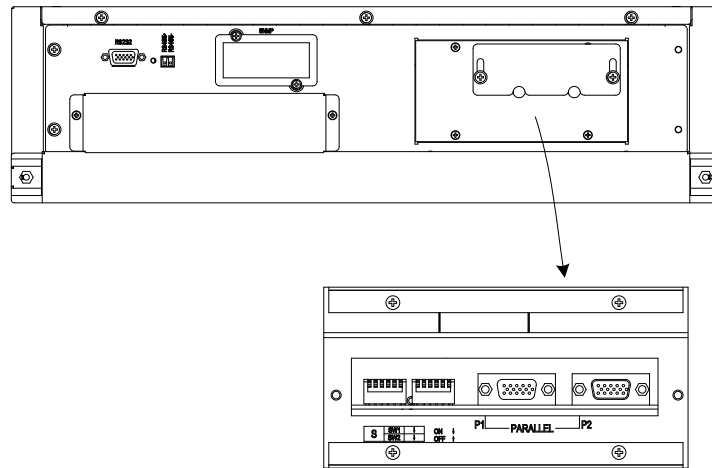

Figure 5-6 Parallel diagram

The parallel interfaces are located in the back panel of the cabinet, open the panel can see. The parallel terminal is shown in Figure



(a) The parallel interfaces of 6-slot cabinet



(b) The parallel interfaces of 8-slot cabinet

Figure 5-6 Location of the Parallel interface

The control cables for the parallel operation must be connected with all single devices to form a closed loop, as is shown in Figure

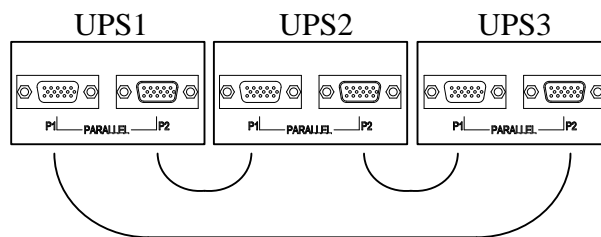

Figure 5-7 Parallel connection

For more details of parallel operation, please refer to the "Instruction for Parallel Operation"

6. Maintenance

6.1. Contents of this chapter

This chapter introduces UPS maintenance, including the maintenance instructions of power module, monitor unit and bypass unit and the replacement method of dust filter

6.2. System maintenance instruction



6.2.1. Matters needing attention

Only maintaining engineers can maintain the power module, monitor unit and bypass unit.

- 1) The power module should be disassembled from top to bottom, so as to prevent any inclination from high gravity center of the cabinet.
- 2) To ensure the safety before maintaining power module and monitor unit, use a multimeter to measure the voltage between operating parts and the earth to ensure the voltage is lower than hazardous voltage, i.e. DC voltage is lower than 36Vdc, and AC maximum voltage is lower than 30Vac.
- 3) Monitor unit and bypass unit is not recommended to hot swap; only when UPS is in Maintenance Bypass Mode or UPS is completely powered off, the monitor unit and bypass unit can be disassembled.
- 4) Wait 10 minutes before opening the cover of the power module after pulling out from the Cabinet.

6.2.2. Instruction for Maintaining Power module

Confirm the UPS is operating in Normal Mode and the bypass is working normally before pulling out the power module needed to be repaired.

- 1) Ensure the remaining power module will not be overloaded.
- 2) Power off the power module:
 - a) Enable. LCD panel->Menu Operate ->Enable Module "OFF" icon 
 - b) Press the "OFF" button on the power module panel for 3 seconds, the power module quits from the system.
- 3) Remove the mounting screw on the two front sides of the power module and pull out the power module by two persons.
- 4) Wait 10minutes before opening the cover for repairing.
- 5) After the repairing is done, push the power module into the cabinet and the power module will automatically join the system.

6.2.3. Maintaining monitor unit and bypass unit for 6-slot cabinet

Confirm the UPS is operating in Normal mode and the bypass is working normally:

- 1) Transfer the system to bypass mode through the LCD control panel.
- 2) Turn on the maintenance bypass breaker. The load is powered through maintenance bypass and static bypass.
- 3) One by one to turn off the battery breaker, input breaker, bypass input breaker and output breaker. The load is powered through maintenance bypass.
- 4) Take out power modules,
- 5) Take out power module
- 6) Use multimeter to measure the voltage value of each terminal of UPS to PE, and ensure that UPS is completely power off so as to avoid electric shock
- 7) After the completion of maintenance, insert power module and tighten the screws on both sides of the power module.
- 8) One by one to turn on the output breaker, bypass input breaker, input breaker and battery breaker.
- 9) After 2 minutes, the bypass indicator LED goes green, and the load is powered through maintenance bypass and static bypass.

- 10) Turn off the maintenance bypass breaker.
- 11) After 30S, the rectifier starts, the rectifier indicator LED goes green, and then inverter starts. After 60S, the system transfers to Normal mode.
- 12) Close Battery Breaker.

6.2.4. Maintaining monitor unit and bypass unit for 8-slot cabinet

UPS is in normal mode, bypassing normal operation :

- 1) Transfer the system to bypass mode through the LCD control panel.
- 2) Close the manual bypass breaker.
- 3) Close the maintenance bypass breaker.
- 4) One by one to turn off the battery breaker, input breaker, bypass input breaker and output breaker. The load is powered through maintenance bypass.
- 5) Use multimeter to measure the voltage value of each terminal of UPS to PE, and ensure that UPS is completely power off so as to avoid electric shock
- 6) Bypass module and cabinet maintenance
- 7) One by one to turn on the output breaker, bypass input breaker, input breaker and battery breaker.
- 8) After 2 minutes, the bypass indicator LED goes green, and the load is powered through maintenance bypass and static bypass.
- 9) Disconnect the maintenance bypass breaker.
- 10) Disconnect the manual bypass breaker. After 30S, the rectifier starts, the rectifier indicator LED goes green, and then inverter starts. After 60S, the system transfers to Normal mode.
- 11) Close Battery Breaker.



Danger

UPS without external power distribution switch could be electrified on manual bypass mod, please don't touch it so as to avoid electric shock.

6.2.5. Battery maintenance

Generally, maintenance free batteries do not require manual maintenance when using. Operate according to certain requirements. The life of the battery can be prolonged. The factors that affect battery life are as follows: installation, temperature, charging and discharging current, charging voltage, discharge depth and long-term charging.

1. Installation. Batteries should be installed as clean as possible, in a cool, airy, dry place, avoiding exposure to direct sunlight or other radiant heat sources. When installing the battery, pay attention to the accuracy and quantity of the battery. The batteries with different specifications and batch numbers should not be mixed.
2. Temperature. Keep the temperature of the battery at about 25°C.
3. Charge discharge current. The optimum charging current of lead-acid battery is about 0.1C, and the charging current must not be greater than 0.3C. Charging current is too large or too small, will affect the battery life. Discharge current is generally required at 0.05~3C.
4. Charging voltage. Because the UPS battery belongs to the standby mode, the battery will be discharged only when the power supply is abnormal or the battery will be charged. To prolong the life of battery charger, UPS generally uses the constant voltage/current limiting control, after the

battery is turned into floating state, each section of the floating voltage set to about 13.7V. If the charge voltage is too high, the battery will be overcharged; otherwise the battery will not be charged enough.

5. Discharge depth. The deeper the discharge depth is, the less cycle times to be, so the depth discharge should be avoided. UPS in the case of light load discharge or no-load discharge will cause deep discharge of the battery.
6. Regular maintenance. The battery should be checked regularly, such as observing its appearance and measuring the voltage of the battery. If the battery is not discharged for a long time, the activity will become worse, so the UPS also needs periodic discharge test to keep the battery active.
7. Check the battery regularly for leakage, deformation and so on.

7. Product Specification

7.1. Contents of this chapter

This chapter provides the specifications of the product, including environmental characteristics mechanical characteristics and electrical characteristics

7.2. Applicable Standards

The UPS has been designed to conform to the following European and international standards shown in Table

Table 6-1 Compliance with European and International Standards

Item	Normative reference
General safety requirements for UPS used in operator access areas	EN50091-1-1/IEC62040-1-1/AS 62040-1-1
Electromagnetic compatibility (EMC) requirements for UPS	EN50091-2/IEC62040-2/AS 62040-2 (C3)
Method of specifying the performance and test requirements of UPS	EN50091-3/IEC62040-3/AS 62040-3 (VFI SS 111)

- **Note**

The above mentioned product standards incorporate relevant compliance clauses with generic IEC and EN standards for safety (IEC/EN/AS60950), electromagnetic emission and immunity (IEC/EN/ AS61000 series) and construction (IEC/EN/AS60146 series and 60950).

7.3. Environmental Characteristics

Table 6-2 Environmental Characteristics

Item	Unit	Requirements
Acoustic noise level at 1 meter	dB	65dB @ 100% load, 62dB @ 45% load
Altitude of Operation	m	≤1000,load derated 1% per 100m from 1000m and 2000m
Relative Humidity	%RH	0-95, non-condensing
Operating Temperature	°C	0-40,Battery life is halved for every 10°C increase above 20°C
UPS Storage Temperature	°C	-40-70
Recommended battery storage temperature	°C	-20~30

7.4. Mechanical Characteristic

The main physical parameters of the cabinet shows in Table

Table 6-3 Mechanical Characteristics for Cabinet

Model	Unit	6-slot Cabinet	8-slot Cabinet
Mechanical Dimension (W*D*H)	mm	482*916*931	482*916*1550
Weight	kg	140	160
color	N/A	Black	Black
Protection Level, (IEC60529)	N/A	IP20	IP20

The main physical parameters of the cabinet shows in Table

Table 6-4 Mechanical Characteristics for power module

Model	Unit	power module
Mechanical Dimension (W*D*H)	mm	436*677*85
Weight	kg	18

7.5. Electrical Characteristics

7.5.1. Electrical Characteristics (Input Rectifier)

The main electrical features of the rectifier are shown in Table

Table 6-5 Rectifier AC input (Mains)

Item	Unit	Parameter
Grid System	\	3 Phases + Neutral + Ground
Rated AC Input Voltage	Vac	380/400/415(three-phase and sharing neutral with the bypass input)
Rated Frequency	Vac	50/60Hz
Input voltage range	Vac	304~478Vac (Line-Line),full load 228V~304Vac (Line-Line),load decrease linearly according to the min phase voltage
Input Frequency range	Hz	40~70
Input Power factor	PF	>0.99
THDI	THDI%	<3% (Full Linear Load)

7.5.2. Electrical Characteristics (Intermediate DC Link)

Table 6-6 Battery

Items	Unit	Parameters
Battery bus voltage	Vdc	Rated : $\pm 240V$
Quantity of lead-acid	Nominal	40=[1 battery(12V)] ,240=[1 battery(2V)]

cells		
Float charge voltage	V/cell (VRLA)	2.25V/cell(selectable from 2.2V/cell~2.35V/cell) Constant current and constant voltage charge mode
Temperature compensation	mV/°C/cl	3.0(selectable:0~5.0)
Ripple voltage	%	≤1
Ripple current	%	≤5
Equalized charge voltage	VRLA	2.4V/cell(selectable from : 2.30V/cell~2.45V/cell) Constant current and constant voltage charge mode
Final discharging voltage	V/cell (VRLA)	1.65V/cell(selectable from: 1.60V/cell~1.750V/cell) @0.6C discharge current 1.75V/cell (selectable from: 1.65V/cell~1.8V/cell) @0.15C discharge current (EOD voltage changes linearly within the set range according to discharge current)
Battery Charge	V/cell	2.4V/cell(selectable from : 2.3V/cell~2.45V/cell) Constant current and constant voltage charge mode
Battery Charging Power Max Current	kW	10%* UPS capacity (selectable from : 1~20%* UPS capacity)

Note: the default number of batteries is 40, please see the UPS battery voltage identification on the nameplate before installation, if the battery number is not 40, please change the settings, and then connect the battery, otherwise the risk of damage. Please contact the manufacturer's customer service phone about the operation steps.

7.5.3. Electrical Characteristics (Inverter Output)

Table 6-7 Inverter Output (To critical load)

Item	Unit	Value
Rated capacity	(kVA)	25-200
Rated AC voltage	Vac	380/400/415 (Line-Line)
Rated Frequency	Hz	50/60
Frequency Regulation	Hz	50/60Hz±0.1%
Voltage precision	%	±1.5(0~100% linear load)
Overload	\	110%, 60min; 125%, 10min; 150%, 1min; >150%, 200ms
Synchronized Range	Hz	Settable, ±0.5Hz ~±5Hz, default ±3Hz
Synchronized Slew Rate	Hz	Settable, 0.5Hz/S ~ 3Hz/S, default 0.5Hz/S
Output Power Factor	PF	0.9
Transient Response	%	<5% for step load (20% - 80% -20%)
Transient recovery		< 30ms for step load (0% - 100% -0%)

Item	Unit	Value
Rated capacity	(kVA)	25-200
Output Voltage THDu		<1% from 0% to 100% linear load <6% full non-linear load according to IEC/EN62040-3

7.5.4. Electrical Characteristics (Bypass Mains Input)

Table 6-8 Bypass Mains Input

Rated capacity	KVA	25-200	
Rated AC voltage	V _{ac}	380/400/415 (three-phase four-wire and sharing neutral with the bypass)	
Rated Current	A	38~303(see Table)	
Overload	%	110%, Long term operation 110%~125%, 5 min 125%~150%, 1min >150%, 1s	
Current rating of neutral cable	A	1.7×I _n	
Rated frequency	Hz	50/60	
Switch time (between bypass and inverter)	mS	≤2mS	
Bypass voltage range	%	Settable, default -20%~+15% Up limited: +10%, +15%, +20%, +25% Down limited: -10%, -15%, -20%, -30%, -40%	Settable, default -20%~+15% Up limited: +10%, +15%, +20%, +25% Down limited: -10%, -15%, -20%, -30%, -40%
Bypass frequency range	Hz	Settable, ±1Hz, ±3Hz, ±5Hz	Settable, ±1Hz, ±3Hz, ±5Hz
Synchronized Range	Hz	Settable ±0.5Hz~±5Hz,default ±2Hz	Settable ±0.5Hz~±5Hz,default ±2Hz

7.6. Efficiency

Table 6-9 Efficiency

Item	Unit	Value	
Overall efficiency			
Normal mode(dual conversion)	%	>96	
ECO mode	%	>98	
Battery discharging efficiency (battery at nominal voltage 480Vdc and full-rated linear load)			
Battery mode	%	>96	

7.7. Display and Interface

The system display and interface are shown in Table

Table 6-10 System display and interface

Display	LED + LCD + Touch screen
Interface	Standard: RS232, RS485, Dry Contact Option: SNMP,

Appendix I.

6-slot cabinet options PDU introduction

PDU is optional for 6-slot cabinet. The fittings can only be configured by the manufacturer.

Size diagram of 6 module cabinet with PDU shows in Figure 0-1

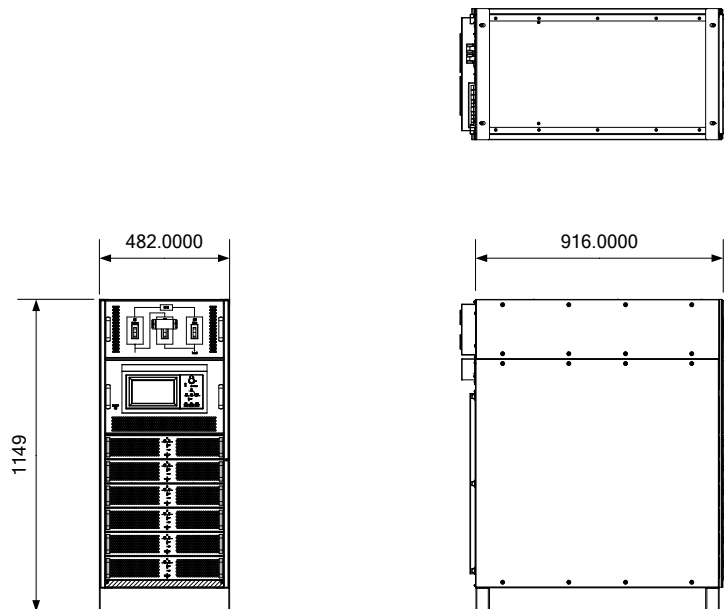
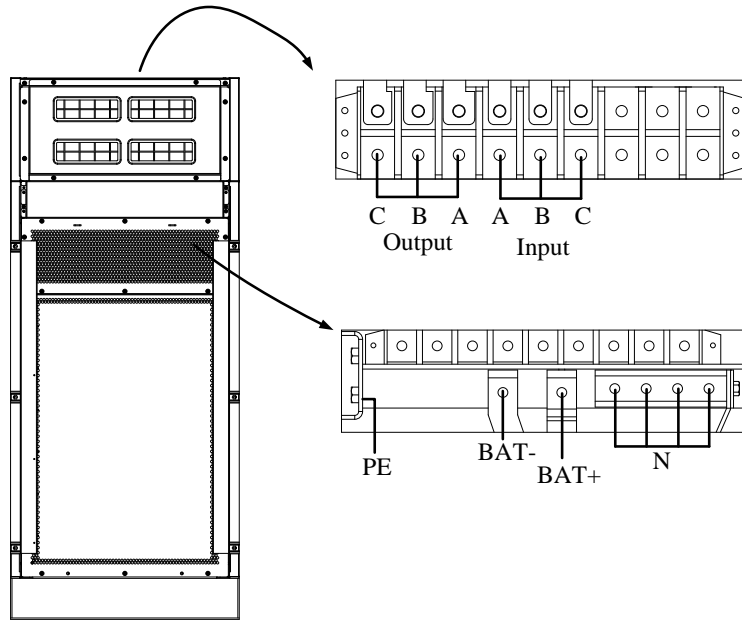
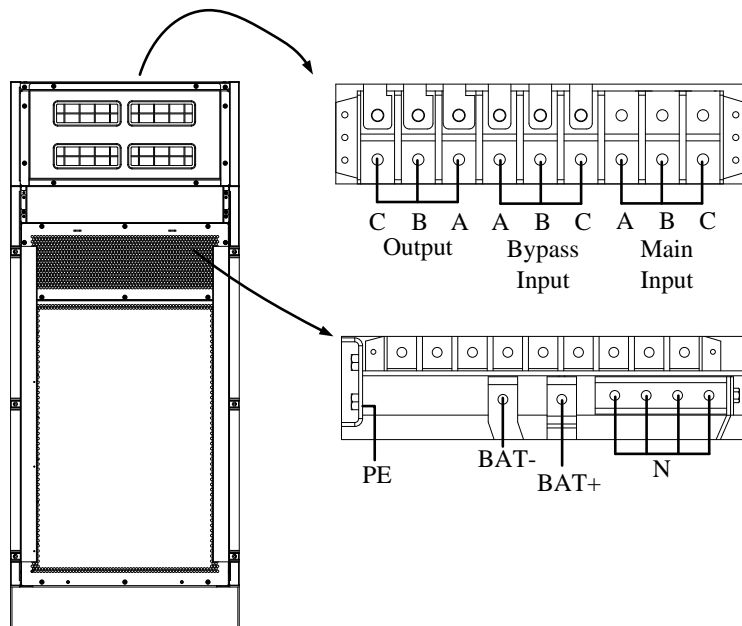

Figure 0-1 Size diagram of 6 module cabinet with PDU

PDU Terminal layouts see Figure 0-2



(a) Layout of single input terminals



(b) Layout of Dual input terminals

Figure 0-2 PDU Terminal layout

PDU only support top cable entry, see Figure 0-3

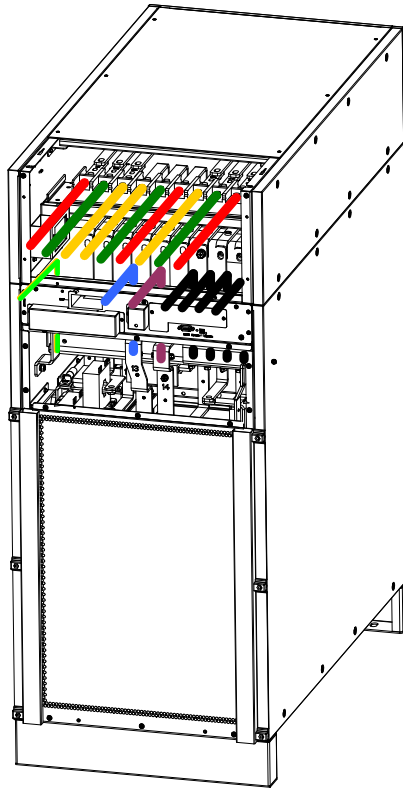

Figure 0-3 PDU Cable entry



SHIELD™

www.shield.systems

© 2017 Shield. Shield logo is a trademarked property of their respective owners. All Rights Reserved Publication No. UM3PB03. Specifications are subject to change without notice. While every precaution has been taken to ensure accuracy and completeness herein, Shield assumes no responsibility, and disclaims all liability, for damages resulting from use of this information or for any errors or omissions.